

# W1M / W1A / W1E - GIESEN COFFEE ROASTERS

## GAS / ELECTRIC COFFEE ROASTER

🔥 NATURAL / PROPANE GAS (W1A / W1M)

⚡ ELECTRIC HEATING (W1E)



### W1A / W1M / W1E

#### COMPACT ROASTERS WITH BIG RESULTS

W1 series roasters combine high quality and extensive functionalities in compact and easy to use machines.

#### AVAILABLE IN THREE TYPES

It's all in the name. Our W1 series is available in three types; W1A, W1E and W1M. All three are commercial roasters designed to deliver consistent roasts, lower emissions and the lowest operating costs. The difference between the different types is that 'A' stands for automatic control, 'E' stands for electric and 'M' stands for manual control. All three roasters are fully customizable in terms of color and details.

<b>ROASTER WEIGHT</b>	150 kg
<b>W1A DIMENSIONS</b>	1330 x 645 x 960
<b>W1E DIMENSIONS</b>	1330 x 500 x 960
<b>W1M DIMENSIONS</b>	1300 x 620 x 960
<b>MINIMUM BATCH SIZE</b>	100 gram (0,1 kg)
<b>MAXIMUM BATCH SIZE</b>	1500 gram (1,5 kg)
<b>MAXIMUM SOUND</b>	70 dB (A)



### GIESEN W1 SERIES

The perfect choice for roasting small batches of high-quality specialty coffee. Enjoy the art of roasting and identify your perfect roast in a small batch. When gas isn't an option, the W1E electric roaster may be the perfect solution for you.

Presentation is key. That's why we designed a beautiful presentation table (optional) to make your W1 stand out. The table is optional in our W1 series and fully customisable. Lots of design options are available like; pick your colour, select a table-top, or add your own design at the side of your table.

# ABOUT GIESEN



## DUTCH CRAFTSMANSHIP

Artisan hand built coffee roasters that are easy to use, reliable and offer you the technology to roast beans with more control than any other coffee roaster available on the market.

## SUPPORT AND SERVICE

Although Giesen is becoming a well-known brand, our way of working remains the same; informal with a personal approach. Dutch craftsmanship, family values, and a no-nonsense mentality.

## UNIQUE DESIGN

We build roasters that make you smile. A roaster that represents you and makes you proud. We offer a lot of design options so you can completely personalize your roaster to your liking.

### UNDERPRESSURE RANGE

80 - 180 Pa (min. - max.)  
Default value: 110 Pa

### DRUM RPM RANGE

46 - 70 Hz (min. - max.)  
Default value: 55 Hz

### TEMP. SETPOINT RANGE

0 - 250 °C (min. - max.)  
Default value: 200 °C

### SUPPLY VOLTAGE W1A / M

230V + N + PE  
Supply frequency: 50 - 60 Hz

### SUPPLY VOLTAGE W1E

3 x 400V + N + PE  
Supply frequency: 50 - 60 Hz

### GAS CONSUMPTION W1A / M

I2L / I2EK	(G25 / G25.3)	1.04 m <sup>3</sup> /h
I2E / I2H / IRE+	(G20)	0.91 m <sup>3</sup> /h
I3P	(G31)	0.35 m <sup>3</sup> /h
I3B/P / I3+ / I3B	(G30)	0.31 m <sup>3</sup> /h

### GAS INLET PRESSURE W1A / M

I2L / I2EK	(G25 / G25.3)	25 mbar
I2E / I2H / IRE+	(G20)	20 mbar
I3P	(G31)	30 / 37 / 50 mbar
I3B/P / I3+ / I3B	(G30)	30 / 29 / 50 mbar

### POWER CONSUMPTION

W1A / M	0.8 kW/h
W1E	7.2 kW/h

### TOTAL STATIC PRESSURE

80 - 180 Pa (min. - max.)

### CHIMNEY WIDTH

ø 80 mm

### INSULATION TYPE

Rockwool, 8 mm

### MAX. EXHAUST TEMP.

80 °C

### MAX. CHIMNEY BENDS

2 bends

### MAX. CHIMNEY LENGTH

Custom-made

## OPTIONAL ADDITIONS

GIESEN PROFILER

PRESENTATION TABLE

SFE FILTER

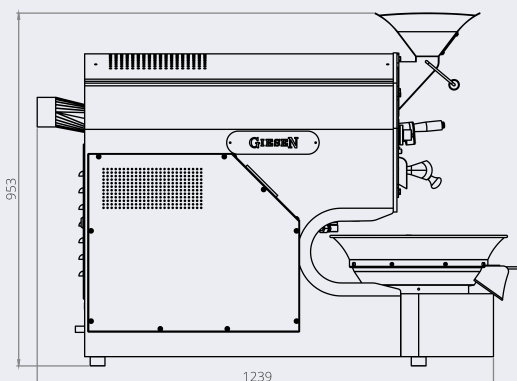
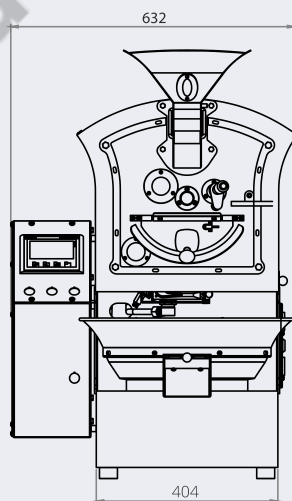

**GIESEN**<sup>®</sup>  
coffee-roasters

### GIESEN COFFEE ROASTERS

+31 (0) 315 68 13 77  
Industrieweg 15  
7071 CK Ulft  
The Netherlands

### ONLINE

info@giesen.eu  
www.giesen.eu



### SALES

sales@giesen.eu

### SUPPORT

support@giesen.eu