

Coffee Roaster Two Pound Model (CR2)

User's Manual
Model 2100, 2200, 2300, 2400



Coffee Kinetics, LLC.
www.sonofresco.com

Patent Pending

This Manual Must Be Retained For Future Reference

WARNING

IF YOU SMELL GAS, TURN OFF THE MANUAL SHUT-OFF VALVE FROM THE PROPANE (LP) OR NATURAL GAS (NG) SUPPLY. DISCONNECT THE ELECTRICAL POWER TO THE APPLIANCE. CALL YOUR LOCAL GAS SERVICE COMPANY TO CHECK THE GAS CONNECTION TO YOUR APPLIANCE.

This WARNING is to be posted in a prominent location close to the appliance.

FOR YOUR SAFETY

DO NOT STORE OR USE GASOLINE OR OTHER FLAMMABLE VAPORS OR LIQUIDS IN THE VICINITY OF THIS OR ANY OTHER APPLIANCE.

WARNING

ELECTRICAL GROUNDING INSTRUCTIONS

THIS APPLIANCE IS EQUIPPED WITH A THREE-PRONG (GROUNDING) PLUG FOR YOUR PROTECTION AGAINST SHOCK HAZARD AND SHOULD BE PLUGGED DIRECTLY INTO A PROPERLY GROUNDED THREE-PRONG RECEPTACLE. DO NOT CUT OR REMOVE THE GROUNDING PRONG FROM THIS PLUG. ELECTRICAL GROUNDING MUST BE IN ACCORDANCE WITH THE LOCAL CODES OR IN THE ABSENCE OF LOCAL CODES WITH THE NATIONAL ELECTRICAL CODE, ANSI/NFPA

WARNING

KEEP THE AREA AROUND THE APPLIANCE FREE AND CLEAR FROM COMBUSTIBLE MATERIALS. MINIMUM CLEARANCE TO ADJACENT COMBUSTIBLES SHALL BE 3 INCHES FROM THE SIDE AND BACK OF THE APPLIANCE.

WARNING

THIS APPLIANCE REQUIRES SUFFICIENT AIR FOR COMBUSTION, ROASTING AND VENTILATION. DO NOT OBSTRUCT THE FLOW OF AIR TO THE BACK VENTILATION PANEL.

AVERTISSEMENT

UNE INSTALLATION, UN AJUSTEMENT, UNE ALTERATION, UN SERVICE OU UNENTRETIEN NON CONFORME AUX NORMES PEUT CAUSER DES DOMMAGES A LA PROPRIETE DES BLESSURES OU LA MORT. LIREZ ATTENTIVEMENT LES DIRECTIVES D'INSTALLATION OU L'ENTRETIEN DE CET EQUIPEMENT.

AVERTISSEMENT

DIRECTIVES POUR LA PRISE DE COURANT ELCTRIQUE
CET APPREIL EST MUNI D'UNE FICHE A TROIS BRANCHES (PRISE DE COURANT) AFIN DE VOUS PROTEGER DES CHOCS ET DOIT ETRE BRANCHE; DIRECTEMENT DANS UN RECEPTACLE ADE-
QUAT DE PRISE DE COURANT A TROIS BRANCHES. IL NE FAUT PAS COUPER OU ENLEVER UNE
BRANCHE DE CETTE FICHE.

ANSI Z83.11 (1996) CGA 1.8 (M96) MANAGER SERVICE EQUIPE

DESTINE; A UN USAGE AUTRE QUE DOMESTIQUE

INSTALLATION

INSTALLATION OF THIS APPLIANCE MUST CONFORM TO LOCAL CODES. IN THE ABSENCE OF LOCAL APPLICABLE CODES IT MUST COMPLY WITH THE NATIONAL FUEL GAS CODE, ANSI Z223.1, NATIONAL GAS INSTALLATION CODE, CAN/CGA-B149.1, OR THE PROPANE INSTALLATION CODE, CA/CGA-B149.2, AS APPLICABLE, INCLUDING:

- THE APPLIANCE MUST BE ISOLATED FROM THE GAS SUPPLY SYSTEM WITH ITS INDIVIDUAL MANUAL SHUT-OFF VALVE.
- THE APPLIANCE AND ITS INDIVIDUAL SHUT-OFF VALVE MUST BE DISCONNECTED FROM THE GAS SUPPLY SYSTEM DURING ANY PRESSURE TESTING OF THAT SYSTEM AT TEST PRESSURES IN EXCESS OF 0.5 PSI. (3.45 kPa).
- THE APPLIANCE MUST BE ISOLATED FROM THE GAS SUPPLY BY CLOSING ITS INDIVIDUAL MANUAL SHUT-OFF VALVE DURING ANY PRESSURE TESTING OF THE GAS SUPPLY PIPING SYSTEM AT TEST PRESSURES EQUAL TO OR LESS THAN 0.5 PSI (3.45 kPa).

OPERATION

SOME UNUSUAL CONDITIONS, SUCH AS NOT CLEANING THE CHAFF COLLECTOR AFTER EACH ROAST, DRASTICALLY OVERFILLING THE ROAST CHAMBER, OR BLOCKING THE ROASTER VENT, CAN CAUSE A FIRE IN THE ROASTING CHAMBER. DO NOT LEAVE THE ROASTER TO RUN UNATTENDED. IN THE EVENT OF A FIRE, TURN OFF THE GAS SUPPLY AND ELECTRIC POWER AND ALLOW THE ROASTER TO COOL COMPLETELY BEFORE TOUCHING IT.

TO REDUCE THE RISK OF FIRE OR ELECTRICAL SHOCK, DO NOT EXPOSE YOUR ROASTER TO RAIN OR MOISTURE.

DO NOT REMOVE THE HOUSING COVER FROM THE ROASTER. THERE ARE NO USER SERVICEABLE PARTS INSIDE. REFER SERVICING TO QUALIFIED SERVICE PERSONNEL.

THIS IS A GAS FIRED APPLIANCE AND MUST NOT BE VENTED INTO A CLOSED SPACE. REFER TO THE INSTALLATION PORTION OF THIS MANUAL FOR PROPER VENTING.

THE GLASS ROASTING CHAMBER AND THE METAL ABOVE THE ROASTING CHAMBER CAN CAUSE BURNS IF TOUCHED DURING THE ROASTING CYCLE.

ROASTERS IDENTIFIED FOR USE WITH NATURAL GAS MUST NOT BE RUN ON PROPANE (LP). DOING SO WOULD POSE A SERIOUS POTENTIAL FIRE HAZARD. BE SURE THAT YOU DO NOT USE A GAS OTHER THAN THE ONE SPECIFIED ON THE NAMEPLATE OF YOUR ROASTER.

ROASTER MANUAL

Roasting with the truly fresh roaster from sonofresco allows you to offer a high quality product and display a truly unique feature to your customers. The sonofresco roaster is an automatic hot air roaster designed to evenly heat coffee beans in a roasting chamber, monitor the roasting process, roast to a desired “roast level”, and cool the roasted coffee beans all in a seventeen to twenty minute cycle, depending on the degree of darkness of the roasted coffee. Although the roaster is automatic, there are procedures involved for proper operation and maintenance. Every user must learn how to correctly operate and maintain the coffee roaster to ensure consistent roasting results.

The information in this manual will prepare you to operate and maintain the coffee roaster and is covered in the following sections:

TABLE OF CONTENT

	Page
1. Introduction	6
2. Installation and Accessories	7
3. Green Coffee	9
4. Things to Remember	9
5. Filling The Roaster and Component Assembly	11
6. Setting the Roast Level and Starting the Roaster	13
7. The Roasting Process	14
8. Handling Roasted Coffee	14
9. Preparing for the Next Roast	15
10. Detailed Chaff Screen Cleaning	17
11. Roast Chamber	18
12. Daily Maintenance	19
13. Error Codes and Troubleshooting	22
14. Troubleshooting	23
15. If you need help	23
16. Replacement Parts	23
17. Hints and Tips	24
18. Warranty Information	26

1. Introduction

Welcome to the world of truly fresh coffee. With your truly fresh coffee roaster, wonderful freshly roasted coffee will soon be a regular part of your life. As a commercial machine, our roaster will dramatically demonstrate your commitment to freshness and quality and your customers will taste the freshest coffee they have ever had.

We are excited about bringing the producers and consumers of the roasted coffee closer together, and restoring the idea of coffee as a locally roasted, and impeccably fresh product.

Depending on the degree of darkness of the roasted coffee and the type of green coffee bean, it should take between seventeen and twenty minutes to roast and cool two pounds of coffee. In a ten hour day, you can easily roast fifty five to sixty pounds of high quality coffee with just one of our machines. (Allow the coffee to sit for 48 to 72 hours before grinding and brewing, to allow the flavor to develop.)

We have written this manual to make learning about our machine a pleasant process. Our company is dedicated to helping you with all the supplies and information you may need.

Three important points to keep in mind:

1. Roasted coffee loses its freshly roasted flavor in about a week, so it is very important to keep track of the age of your roasted coffee. If you are going to sell whole bean coffee, put the “date roasted” right on the bag! Sell it or brew it within a few days of roasting, and the flavor will be genuinely memorable.
2. Always use top quality coffee. You will get better roast consistency, produce less smoke, and get much better flavor out of clean, well-graded, specialty coffees. The difference in price between top quality specialty green coffee and lower quality coffee is definitely not worth the disappointment.
3. Great fresh coffee can be ruined by poor grinding and brewing. Our representatives will be glad to help if you have questions about your brewing equipment or practices.

Happy roasting to you from us ... sonofresco!

The Truly Fresh Team
sonofresco

2. Installation and Accessories

Before installing the coffee roaster, unpack the appliance and read the installation and operation manual.

Locations For your Roaster - Basic Requirements We believe the roaster will prove most valuable to your business if its located where your customers can see it in operation. You may or may not be able to do that, but there are a few essential requirements for the installation of the roaster.

- A. The roaster is not water resistant and should be protected from moisture and wind.
- B. The roaster must be installed not less than three inches from combustibles. The back panel must be free of obstructions to allow for adequate air flow
- C. The roaster must be vented to the outside if installed indoors. See the section on venting options.
- D. It must be reasonably level to operate properly.
- E. If you are at an altitude at or above 4500' please let us know. Some adjustments may be needed to allow the roaster to operate properly at altitudes above 4500'.

Fuel Supply:

The gas supply should be installed, adjusted, and tested by a qualified gas installer.

Propane (L.P.): The LP connection on the back of the roaster is a standard 3/8 inch male flare fitting. **(It is not necessary to use pipe sealant or tape on the flare fitting threads; doing so may cause a leak.)** The roaster is supplied with a hose and regulator assembly for connection to a standard propane bottle with a manual shut-off valve. If you are using a propane roaster indoors, you must comply with any local codes for installing, plumbing, and venting a propane appliance. **DO NOT INSTALL THE PROPANE BOTTLE IN-DOORS; IT MUST BE INSTALLED OUTSIDE ACCORDING TO LOCAL CODES.** The propane supply pressure to the roaster must be adjusted to a minimum of 11 inches water column for the roaster to work properly. A manual gas shut-off valve must be installed at the roaster.

Natural Gas (N.G.): The natural gas roaster is supplied with a ½ inch male NPT fitting for connection to a natural gas supply. Installation and connection to a natural gas line must comply with any local codes. The natural gas supply pressure should be adjusted to a minimum of 7 inches water column flowing or operating pressure for the roaster to work properly. A manual gas shut-off valve must be installed at the roaster.

Electric Power: The roaster must be plugged into a properly wired, grounded, three prong outlet. The roaster only draws 3 amps at 120 volts ac and will not need a dedicated circuit (Note: In some commercial applications a dedicated circuit may be needed if large or multiple commercial appliances are on the same circuit. These types appliances may cause electrical noise that can cause problems with the electronic control.) **Any electrical work should be done by a qualified electrician.** Do not run a 120 volt 60hz appliance on 240 volts 50hz and vice versa.

Venting: The roaster must be vented to the outside when used indoors to prevent the accumulation of Emissions within the dwelling. Venting options include placing the roaster under an existing exhaust hood such as in a commercial kitchen, venting directly into a steel vent pipe, or our vent hood. We recommend the dedicated vent hood shown in Figure 1. The vent hood will allow the roaster to be vented greater distances and will eliminate the possibility of back pressure and wind affecting the roaster caused by direct venting.

VENT HOOD

A vent hood, shown in Figure 1, can be ordered from sonofresco and provides many advantages. First, since it is a powered vent, the exhaust can be vented at greater distances without the risk of back-pressure into the roaster. Second, the exhaust can be tied into existing ducting without back-pressure issues, and third, strong wind pressure against the outside vent will not pose a problem to the roaster. The basic hood installation is shown in Figure 1. Please contact sonofresco for more details on venting the coffee roaster with a vent hood.

VENT KIT

A vent kit, shown in Figure 2, can be ordered from sonofresco.

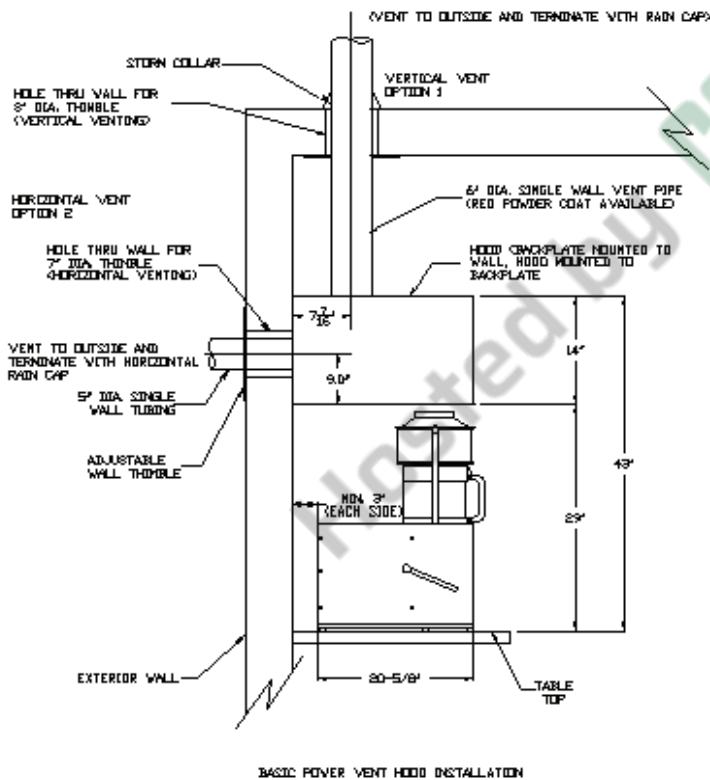

Figure 1

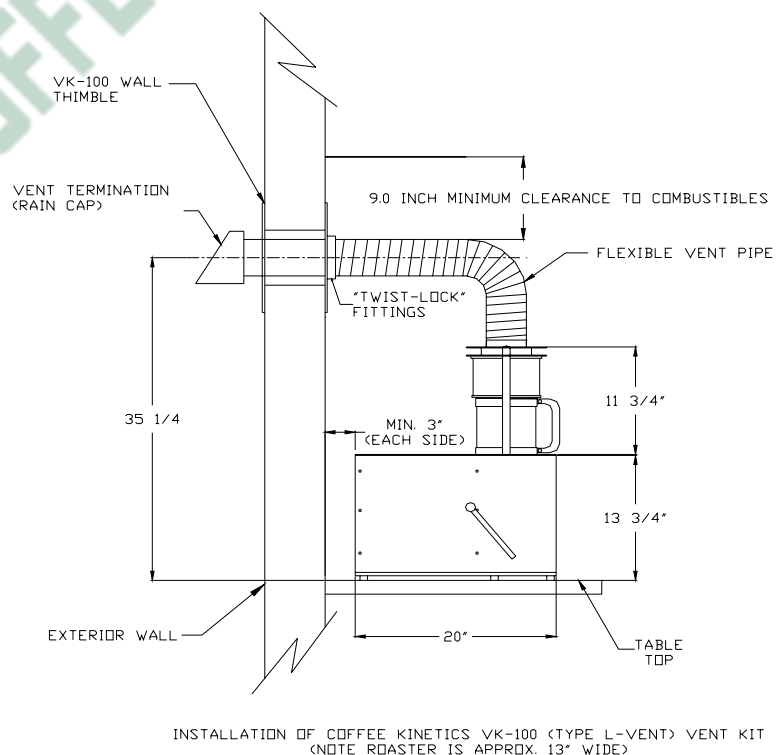

Figure 2

3. Green Coffee

It is important to know that not all green coffees are equal. While most green coffees will roast well in our machine, some poorly processed coffees will not. Sonofresco maintains a good variety of excellent specialty green coffees that have been tested for suitability for our roaster.

The roaster is designed to roast normally processed (washed or dry-process) coffees, which produce a certain amount of chaff towards the end of the roasting cycle. Decaffeinated coffees, which have no chaff, should roast fine in the roaster. If you are having problems roasting decaffeinated coffees, contact us and we will help guide you in the right direction.

4. Things To Remember

The coffee roaster has been designed to be simple to operate. But before you start you must understand some basic principles of operation.

- **Do not use the power button to stop a roast.** If a roast appears to be going too dark, just turn off the “Gas” switch, located on the control board, and the roaster will begin its normal cooling cycle. Turning off the “power” switch will prevent the beans from cooling, and they will begin to smolder and generate smoke. **Always allow the roasted beans to cool before removing them from the roaster.**
- **Always use the measuring can supplied with the roaster.** Fill two cans, level to the top, with green beans. This is approximately 2.8 pounds of green coffee and will yield approximately 2.4 pounds of coffee roasted on a # 5 setting. **Do not overfill the cans, under fill the cans, or use a can other than the one supplied with the roaster. Doing so will cause inconsistent results and loss of coffee.** If the can is lost, please contact us for a replacement.
- **Keep the roaster clean.** Refer to the **Roaster Maintenance section** for proper cleaning procedures. It is important to maintain the roaster to keep it operating at its best.
- **Do not leave the roaster to run completely unattended.** As with any appliance, unusual conditions such as a power outage, blocked vent, or failure to properly maintain the roaster can cause coffee to smolder and generate smoke in the roast chamber. It is good practice to be within earshot of the roaster when operating so you can respond if any of these conditions should occur.
- **Be careful not to chip or scratch the glass roasting chamber.** The roasting chamber is made of very high quality ceramic glass which is capable of handling thermal stress greater than that produced by the roaster. The glass will not however handle thermal cycles after being damaged due to impact or abrasion. The roasting chamber must be handled with care at all times. **Sonofresco will not be held liable for breakage.**

ROASTER COMPONENT DESCRIPTIONS

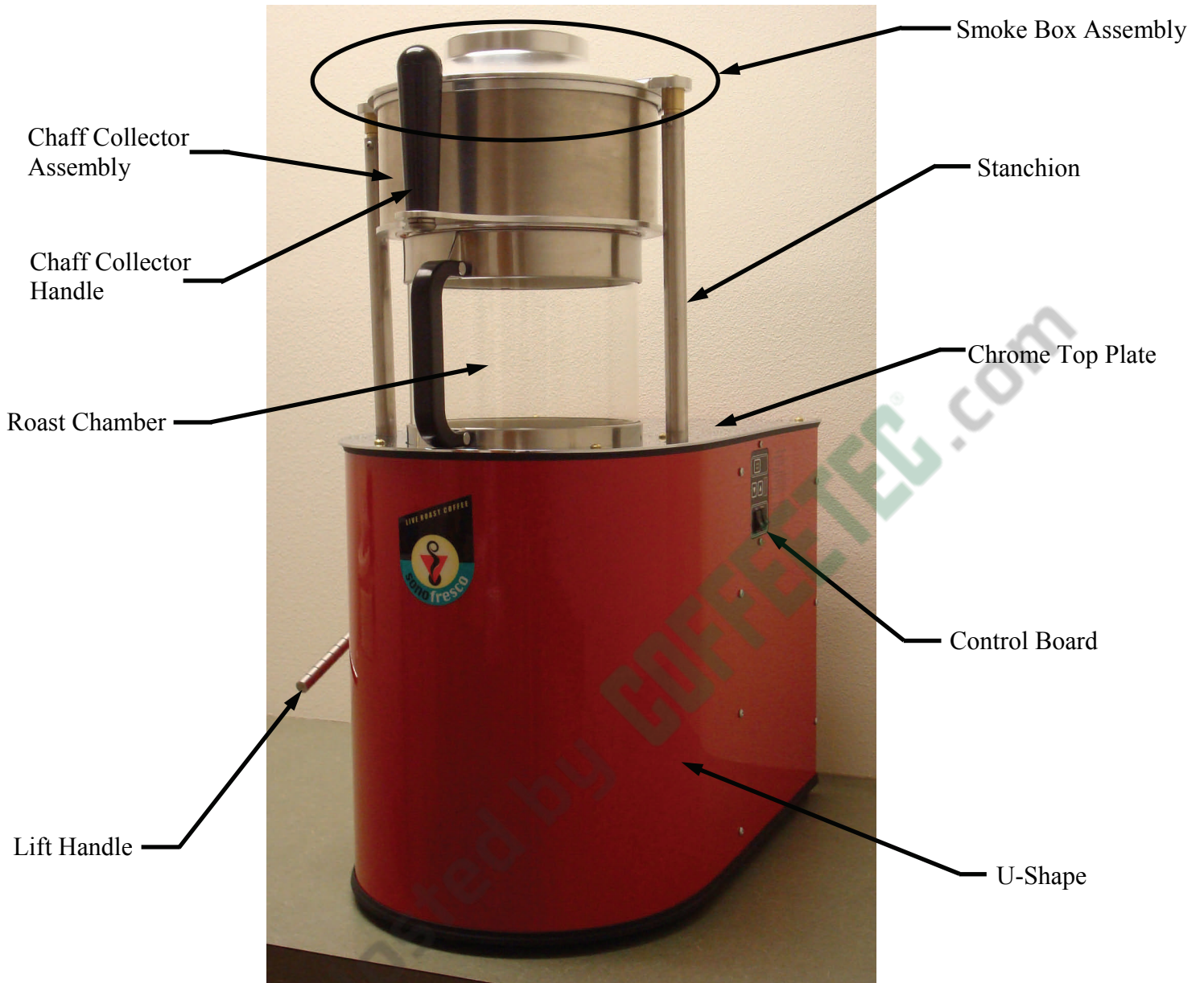

Two Pound Coffee Roaster CR2



Chaff Collector Assembly

5. Filling The Roaster and Component Assembly

Remove Roast Chamber/Chaff Collector Assembly

- Lift handle to raise smoke box assembly. (The smoke box will rise approximately 3/4".)
- Remove roast chamber/chaff collector by lifting straight up and back.

Caution: The roast chamber is able to withstand much higher temperatures than the roaster is capable of producing. However, it can be damaged if impact occurs on a hard surface and then subsequently heated during a roast.

Lift handle



The roaster is designed to operate correctly with a fixed volume of approximately 2.8 lbs of green beans in the roast chamber and is easily measured using the supplied metal can. This volume ensures correct air flow balance through out the entire roasting process. The following steps will ensure that the correct volume of coffee beans are used for each roast.

- Fill the supplied measuring can level to the top.

Caution: The supplied can must be used in order to achieve the correct volume of beans.

- Empty contents of level filled can into roast chamber.



Assemble the Chaff Collector

After adding the correct volume of beans to the roast chamber, assemble the chaff collector and place it on the roast chamber. The chaff wall ends seal to the chaff collector base and screen grooves to prevent air and chaff from escaping from the roaster. The completed chaff collector assembly then seals to the top rim of the roast chamber.

- Set one of the chaff wall ends into the chaff collector groove.
- Set the chaff screen groove onto the end of the chaff wall.
- Place the chaff collector assembly on top of the roast chamber ensuring that the rubber seal seats against the top rim of the roast chamber.
- Completed roast chamber/chaff collector assembly.

Note: Use two hands when placing chaff collector assembly onto roast chamber.

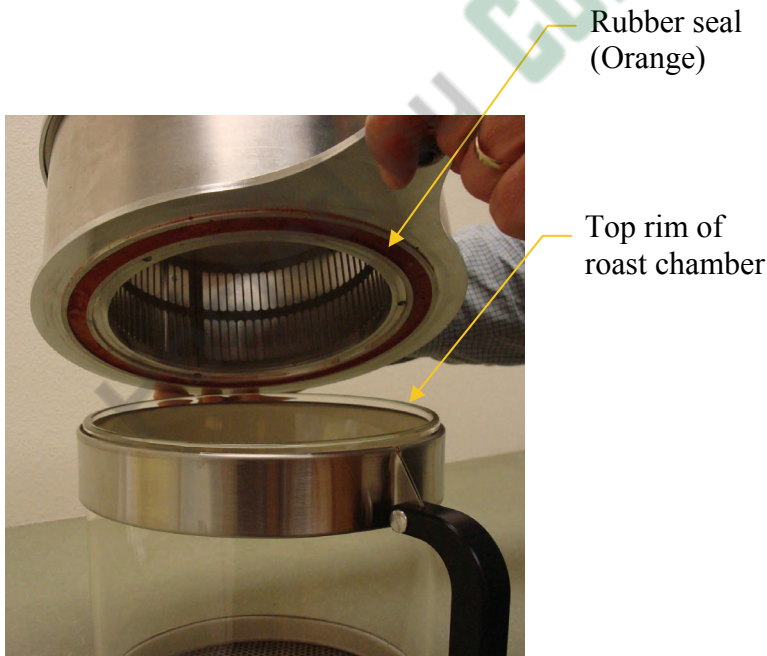
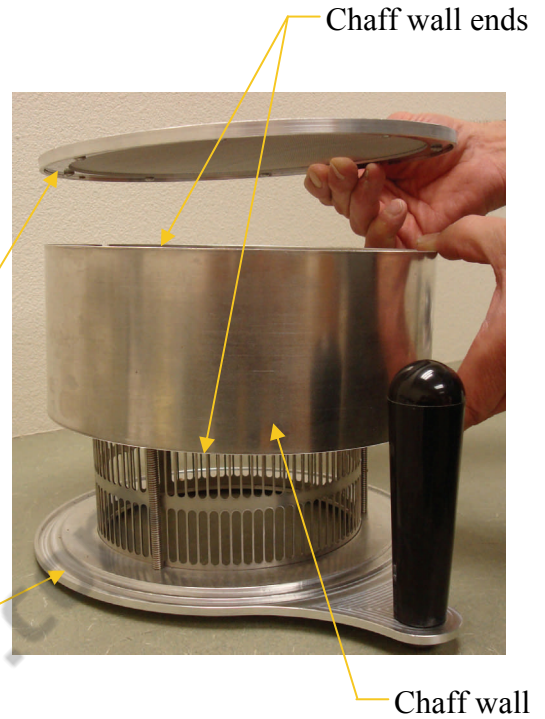

6. Setting the Roast Level and Starting the Roaster

Roaster Controls: The roaster is controlled by an electronic control board that monitors the roasting process based on information provided by the temperature sensor (RTD) and allows the coffee to roast to a predetermined temperature/roast level based on the setting selected by the user. The control board consists of the following user controls and display:

Power Switch	Controls the power to the appliance.
Gas switch	Activates the gas in stand-by mode. (Will not actively turn gas on.)
Down Arrow	Lowers the roast level with each press.
Up Arrow	Increases the roast level with each press.
LED Display	Displays current roast level setting. (Also provides time vs. temperature feed back as discussed in section 17.)

Initiate the roast with three simple steps:

1. Switch the power and gas switches to the **on** position.
2. Select the desired roast level for the coffee being roasted, using the up/down arrow buttons.
3. Push and release the start roast button.

1. Switch the power and gas switches to the on position.

2. Select desired roast setting.
(0-9)

3. Push and release the start roast button.

Roaster will start roasting automatically.



7. The Roasting Process

Once the start button is pushed, the roaster will start roasting automatically and the following will be observed during the process:

- The blower will immediately turn on and the beans will bounce (fluidize) around in the roast chamber. The beans should appear to “swirl” or rotate around the roast chamber indicating that the beans are mixing properly.
- Approximately 5 seconds after the start button is pushed, a decimal point will come on in the lower right hand side of the LED display indicating the control is cycling the gas on.
- At approximately 15 seconds after start, the gas will ignite indicated by a slight “puff” sound and heat in the roast chamber. **Note:** It is not uncommon for the inside of the roast chamber to look wet at the beginning of the roast cycle. This is simply condensation caused by a cold roaster and will dissipate quickly and will not affect the roaster performance.
- The roaster is now automatically roasting the coffee and will continue to cycle the gas on/off approximately twelve times during the active roast cycle to gradually increase the bean temperature closer to the final roast level.
- During the roasting process, the beans will go through changes in color, size, and weight.
 - **Color:** As the bean temperature increases, the first noticeable difference is the darkening color from green to light brown and then to dark brown with oils on the bean surface on the higher settings. **Note:** Decaffeinated coffee will look brown before roasting due to the decaffeination process.
 - **Size:** As the bean is heated, the internal cell walls of the bean will expand from the heat and cause the bean to increase in size by nearly a third. This expanding of the bean is referred to as the “crack” and can be heard as a light snapping or cracking sound, typically occurring first around seven minutes and again near ten minutes (i.e. first crack and second crack).
 - **Weight:** Before roasting begins, the bean is considered “heavy” or “green” due to the moisture trapped inside. During the roasting process the moisture is driven out of the bean. Towards the end of the roast the beans will appear to be bouncing around the roast chamber more rapidly due to the “weight loss”.
- At approximately eleven minutes, the beans will reach the final roast level temperature at which time the electronic control board will automatically cycle the gas off and enter the cool down cycle. During the cool down cycle, the blower continues to circulate air until the beans are cool enough to be handled (approximately seven minutes).
- After the cooling cycle is completed, the blower will shut down and the roaster will go into standby until the start roast button is again pressed.

8. Handling Roasted Coffee

After the roasting and cooling process is completed, the beans can be placed directly into a bag or bin.

Freshly roasted coffee must be allowed to sit for 48 hours before grinding and brewing to allow the flavor to “develop”. This process, known as “degassing”, allows the gasses to escape as the flavors emerge in the bean.

Proper handling should include allowing the beans to sit in a covered but **unsealed** bin before use. If the bin is sealed tightly, the gases cannot escape and the flavor development process will slow. Do not allow the beans to become wet or come into contact with syrups.

9. Preparing for the Next Roast

The roaster components will need to be cleaned prior to starting the next roast to ensure that each roast will be consistent with previous batches. The following is a description of the fundamental operation and the maintenance required between roasts. The entire process should take no more than one minute to complete.

As discussed, the bean will expand and increase in size during the roasting process. During this expansion phase the bean will “crack” and shed its “skin” also known as chaff (the outer skin of the coffee bean). This chaff is captured by the fine mesh of the chaff screen to prevent it from being blown into the vent system. The chaff also acts to balance the air flow in the system as the bean becomes lighter during the roast due to the moisture being driven off. The chaff screen is designed to catch the chaff but allow the hot roasting gases to pass through the chaff screen and out the vent system. Restricting the flow of roasting gases through the screen will lead to darker and darker roasts. Restrictions are created if the chaff is not removed from the screen between roasts or if the oils that are deposited on the wires of the screen are not removed.

The following maintenance summary will prevent the build up of oils on the screen. Detailed steps are outlined on the following page.

- Remove chaff collector from the roast chamber and set it upside down on a table.
- Vacuum chaff from the chaff collector.
- Remove chaff collector and place on table right side up.
- Vacuum the balance of chaff from the chaff screen.
- Clean loose chaff from chaff collector groove using wire brush.
- Clean inside and both ends of chaff wall with a dry terry cloth or paper towel to remove loose chaff.
- Clean chaff screen with wire brush. (See chaff screen cleaning details.)

9. (Continued)

- Remove the chaff collector from the roast chamber and set it upside down on a table.
- Vacuum the chaff from the chaff collector.



- Remove chaff collector and set on table right side up.
- Vacuum balance of chaff from the chaff screen.



- Clean loose chaff from chaff collector groove using wire brush.

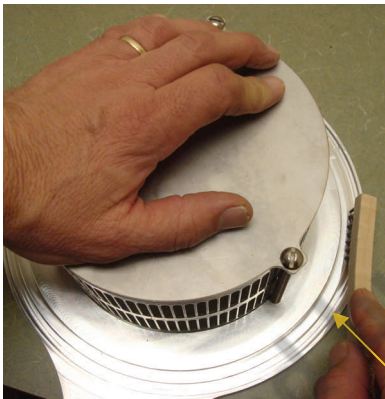

Chaff collector groove

- Clean inside and both ends of chaff wall with dry terry cloth or paper towel to remove loose chaff.



- Clean chaff screen with wire brush. (See chaff screen cleaning details on following page.)

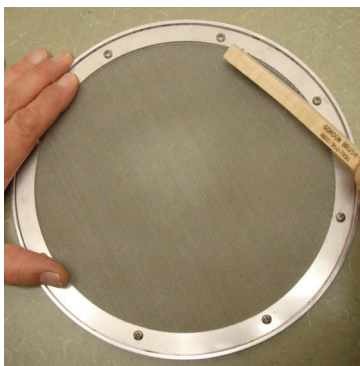

- Cleaned and reassembled chaff collector assembly.



10. Detailed Chaff Screen Cleaning

The chaff screen consists of a wire mesh screen held in place by an aluminum outer ring. The mesh screen is simply wires woven together to create a wire grid. Each of these wires collect chaff and oil from the beans during the roasting process and must be cleaned to allow air to flow freely. A brass wire brush is used to clean the wires as well as the chaff screen groove. (See detail below.) Cleaning is accomplished by aggressively scrubbing both sides with a wire brush around the perimeter (outside edge) of the ring and then cleaning the wires in both directions.

- Clean chaff screen groove to prevent chaff build up. This buildup could affect the seal with the chaff wall.
- Clean the screen where it meets the groove around the entire perimeter of the screen.

Note: It is important that the screen is cleaned all the way to the outer edge where it meets the ring.

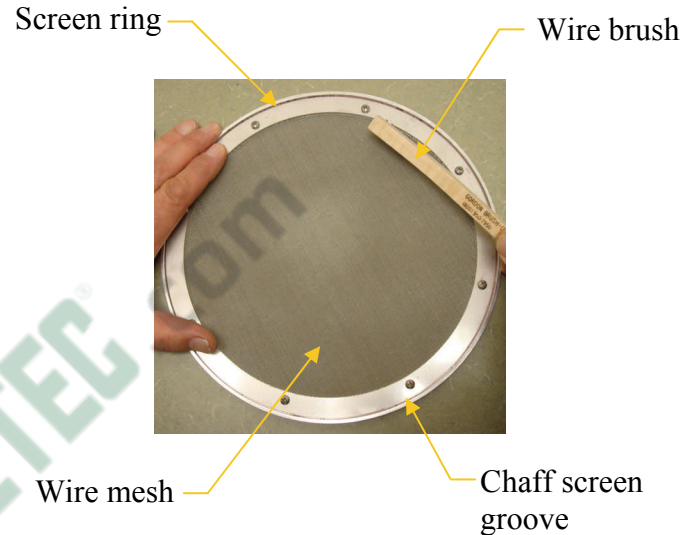

- Use the wire brush to scrub in the direction of the wires to ensure the entire surface of the screen is cleaned.

Note: A fine dust (dried oils from the beans) will be deposited on the table under the screen which indicates the cleaning is being done correctly.

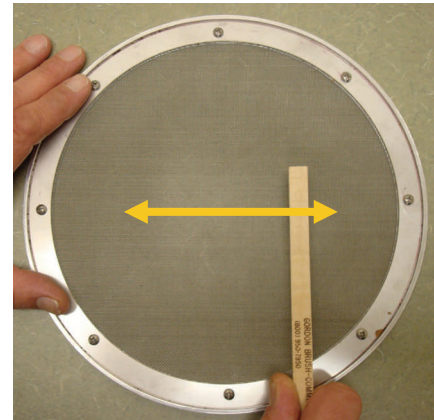

- Turn the brush 90 degrees to clean the wires going in the other direction.
- After completing the cleaning flip the screen over and repeat on the other side.
- Soak the screen in a commercial cleanser, such as Purocaf, weekly to remove excess oils.

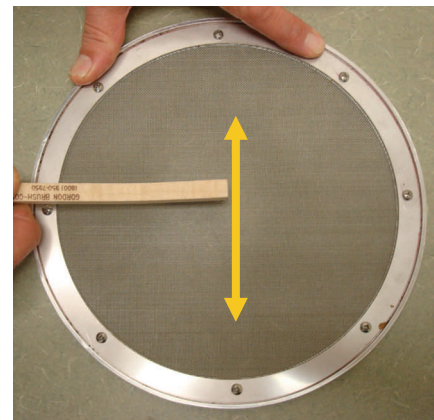

11. Roast Chamber

It is important that the roast chamber be cleaned after every roast to prevent the build-up of oils on the glass surface as well as the bottom plate. Oil build-up is not only unsightly, it will also affect the roaster performance if the build-up becomes excessive. The beans must move around freely in the roast chamber to properly mix with hot air for an even and consistent roast throughout all of the beans. Oils deposited on the glass cylinder and bottom plate create a rough surface that can cause the beans to slow down in the roast chamber due to friction. This “slowing” of the beans can cause darker and inconsistent roasts. Wiping the roast chamber glass and bottom plate with a **dry** terry cloth or paper towel after every roast will reduce the build-up of oils.

Caution: The roast chamber is one of the more costly components of the roaster. Care must be taken when handling to prevent damage or breakage.

- With a firm grip on the roast chamber, wipe the entire inside surface of the roast chamber.
- To prevent breakage, avoid resting the roast chamber on a table or counter top during cleaning.



- With a firm grip on the roast chamber; wipe the bottom surface of the roast chamber.

Note: Some heat discoloration on the bottom plate is normal.

- At the end of the day, clean the entire roast chamber inside and out with a towel, warm water, and mild detergent to completely remove excess oils.



Note: It is not recommended that the roast chamber be soaked as this will affect the gaskets.

12. Daily Maintenance

Daily maintenance is important to keep the roaster operating and looking its best. A maintenance routine at the end of every roasting day will allow the roaster to be begin operation the next morning without delay.

- The daily maintenance includes:
- Clean the chaff collector assembly as you would in between roasts.
 - Clean the entire roast chamber inside and out with a towel, warm water, and mild detergent to completely remove excess oils.
 - Clean temperature sensor with a **DRY** 3M pad (Scotchbrite).

Note: It is very important that the temperature sensor does not get wet. Failure to follow this simple rule will result in temperature sensor damage and risk of burning coffee.

- Clean smoke box assembly with a damp 3M pad (Scotchbrite).
- Clean external surfaces of the roaster, u-shape, chrome top etc., with a damp cloth and mild detergent.
- Clean the area around the roaster to minimize the chaff build-up in the work area.

Temperature Sensor

The temperature sensor plays a critical role in the roaster's operation by measuring the current temperature of the beans and sending the information to the control board. The control board then interprets this information and cycles the gas on/off accordingly, thus ensuring that the beans roast evenly during the cycle following the 'Roast Profile'. If the temperature sensor sends inaccurate information to the control board, the outcome of the roasting process will likely be different than expected.

Example: The coffee beans are actively roasting at a temperature of 200°C (near the end of the active roast cycle), but the temperature sensor is only reading and sending a temperature of 195°C to the control board. The control board is designed to allow the beans to reach a set temperature at a given time, so the control only seeing 195°C continues to roast the beans. The beans at this point are near the end temperature, but are allowed to further roast creating a much darker than expected roasted coffee.

Although the temperature sensor and control board are operating correctly, they are actually lagging behind the coffee's actual temperature. The most common reason for this is that the temperature sensor is being insulated from the heat of the beans due to excess build-up of chaff and oils. Similar to wearing a jacket in the winter, keeping the cold out and body heat in, we are slowing down how fast the heat gets to the temperature sensor. Again, this "lag" causes the coffee to over roast or burn.

Cleaning the Temperature Sensor

The two most important items to properly maintain are the screen and the temperature sensor.

The temperature sensor is delicate and should be handled with care. Clean only the ceramic end of the sensor; do not bend the wires. It is also important not to move the sensor from its location. Clean the temperature sensor with a **dry** 3M pad folded in half over the white portion of the sensor. Rub the sensor back and forth as if you were sanding a pencil; only apply enough pressure to remove the chaff and oils. The sensor will tend to turn almost black after a day of roasting; clean the sensor as close to white as possible. (Discoloration to a light brown or beige is normal. The sensor should be cleaned to that color.)

- Fold the 3M pad around the sensor.
- Rub the sensor back and forth to remove chaff and oil deposits.

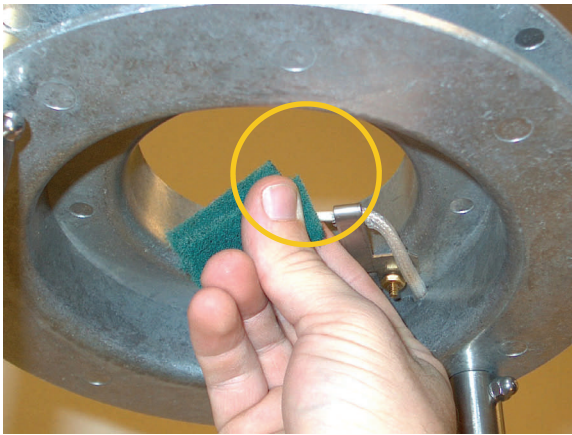

Temperature sensor
(RTD)



3M pad
(Scotchbrite)

DO NOT ALLOW THE TEMPERATURE SENSOR TO GET WET DURING CLEANING. DOING SO MAY CAUSE DAMAGE.

- Wipe the inside of the smoke box assembly using a damp 3M pad.
- Every night, the assembly should be cleaned down to the metal finish.
- Wipe the entire outside of the roaster with a cloth and mild detergent.
- Clean the chaff from around the roaster work area.

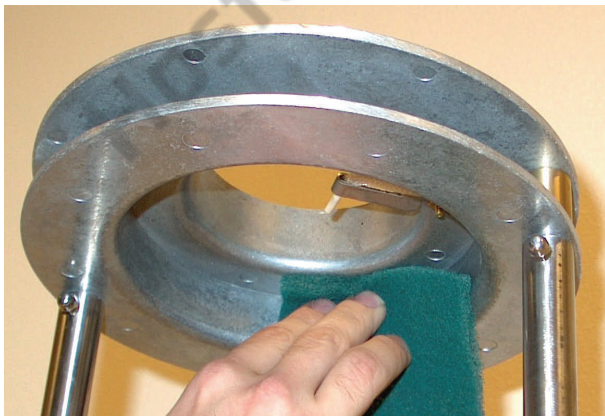

ROASTER MAINTENANCE SUMMARY

Schedule and follow these maintenance steps for trouble free roaster operation:

<u>Maintenance Item</u>	<u>Action</u>	<u>Frequency</u>	<u>Page Number</u>
Chaff Screen	<ul style="list-style-type: none">• Clean with wire brush• Soak in commercial cleanser	<ul style="list-style-type: none">• After every roast• Once week	17
Temperature Sensor	<ul style="list-style-type: none">• Clean sensor with dry 3M pad (Scotchbrite)	<ul style="list-style-type: none">• Daily	20
Smoke Box Assembly	<ul style="list-style-type: none">• Clean surfaces with 3M pad (Scotchbrite)	<ul style="list-style-type: none">• Daily	20
Roast Chamber	<ul style="list-style-type: none">• Clean with soft cloth• Clean with warm water & mild detergent	<ul style="list-style-type: none">• After each roast• Daily	18
Chaff Collector	<ul style="list-style-type: none">• Clean chaff wall groove	<ul style="list-style-type: none">• After each roast	16
Outside Surfaces	<ul style="list-style-type: none">• Clean top panel and U-shape with mild commercial cleanser	<ul style="list-style-type: none">• Daily	20

13. Error Codes and Troubleshooting

The roaster employs a series of five error codes displayed on the control board LED display. An error code is read on the display in series. Example, the error code “E1” would be displayed as a backwards three or E, a pause, and then 1. The code will continue to flash “E1”...”E1”...etc. until the power is cycled off and then on again. In the case of an “E1”, an out of range temperature sensor, the error will not clear unless the problem with the temperature sensor is resolved.

The following table describes each error code and the probable cause. The most common errors are an “E1”, meaning a temperature sensor was likely damaged during cleaning, and an “E2”, meaning the gas valve was most likely not turned on before starting a roast. In the event of an error code “E3” and “E4”, the electronic control board will end the heating cycle and enter the cool down cycle. However, an “E1” and “E5” error codes will result in both the gas as well as the blower to be turned off without entering the cool down cycle. An “E5” indicates that the temperature continues to increase at the end of the active roast cycle rather than decrease as it should during the cool down cycle. The increase in temperature after the roast cycle may indicate the beans are scorched or on the verge of a fire. If the blower remained on, a fire could result. Follow the steps below to prevent excessive smoke from the beans to accumulate in the shop.

- Remove roast chamber/chaff collector assembly from the roaster. **Caution:** The roast chamber assembly will be hot. Grasp only the roast chamber handle when removing the assembly from the roaster.
- Dump beans including the chaff assembly onto/into a non combustible area or receptacle. (Outside on pavement would be a safe place.)

Hosted by COFFEETEE.COM

14. Troubleshooting

ERROR CODES

<u>Error Code</u>	<u>Problem</u>	<u>Cause</u>	<u>Solution</u>
E-1	<ul style="list-style-type: none">Electronic control has detected an “out of range” condition on the temperature sensor.	<ul style="list-style-type: none">Broken wire, short in the wiring, or a broken or defective temperature sensor.	<ul style="list-style-type: none">Replace temperature sensor.
E-2	<ul style="list-style-type: none">Temperature sensor has not detected a sufficient increase in temperature.	<ul style="list-style-type: none">Problem with the gas supply.Dirty temperature sensor.Interference with airflow.	<ul style="list-style-type: none">Check gas shutoff valve or propane supply.See section on cleaning sensor.Clean screen, check exhaust, use correct amount of beans.
E-3	<ul style="list-style-type: none">The roast did not reach its set point in twenty minutes.	<ul style="list-style-type: none">Gas supply.Dirty temperature sensor.	<ul style="list-style-type: none">Check shut off valve.Check gas supply pressure.Clean temperature sensor.
E-4	<ul style="list-style-type: none">Failure to achieve ignition later in the roast cycle.	<ul style="list-style-type: none">Likely cause is the propane supply ran out.Gas supply is shut off after roaster has started.	<ul style="list-style-type: none">Refill propane tank.Open gas shutoff valve.
E-5	<ul style="list-style-type: none">Temperature rises after the end of the roast cycle. May indicate a presence of fire.	<ul style="list-style-type: none">Overfilling the roast chamber.Neglecting to clean the chaff screen or chaff collector.	<ul style="list-style-type: none">Use recommended amount of beans.Clean chaff collector and screen after each roast.

15. If You Need Help

If you have done your best to work out a problem or question, and still are not able to solve it, we will be glad to help. Call us at (360)757-2800 or contact us by email at office@sonofresco.com

16. Replacement Parts

A number of replacement parts are available through sonofresco, including new roasting chambers, new chaff collector screens, temperature sensors, control boards and other items. You may want to have spare screens or roasting chambers on hand to avoid interruptions in production. Contact your local representative or the sonofresco office for prices and availability.

17. Hints and Tips

Roast Profile: One way to further understand and monitor the roaster operation is by viewing the roast profile. The electronic control board is designed to control the rate at which the coffee temperature rises over time. The roast profile is basically a time versus temperature graph that determines when the gas is cycled on to heat the beans and then cycled off to prevent the beans from heating too quickly. The gas is cycled an average of twelve times during the active roast. The roast profile also acts in conjunction with the roast level settings to finish the roast at a specified temperature within a specified amount of time (plus or minus 15 seconds) and enter the cool down phase. The roast profile data can be viewed via the LED display and referenced to the graph on the following page.

Roast Profile Data

Time Measurement: The time measurement is the time from the beginning of the roasting process when the start roast button was pressed.

- During an active roast, push and release the start roast button to display the time.

Example: The roaster is running for 1:30 (one minute and thirty seconds) from start and the roast button is pressed and released the display will scroll 1...-...3...0. (one...dash...three...zero.) This time should be mentally noted; immediately proceed to read the temperature data.

Temperature Measurement: The temperature measurement is the real time temperature of the exhaust at the moment it is viewed during the roasting process.

- During an active roast, simultaneously push and hold both the up and down arrows to display the temperature. Note: If the up and down arrow buttons are continuously held down, the temperature on the display rises as the actual bean temperature rises.

Example: The bean temperature is currently 135°C (one hundred thirty five degrees Celsius); the display will scroll 1...3...5. This temperature should be mentally noted and compared to the graph on the following page.

Graph Comparison: Simply find the time on the bottom edge of the graph and the temperature on the left side. Follow up and across until the lines intersect and plot a dot at that point. This dot represents a point on the time versus temperature graph and should be on or very close to the blue roast profile line.

Although this data is not critical when roasting coffee, you may be asked to perform these readings every thirty to sixty seconds in the event of a service call. The information is used by the technician to diagnose a problem and offer a solution.

SONOFRESCO COFFEE ROASTER ROAST TEMPERATURE PROFILE

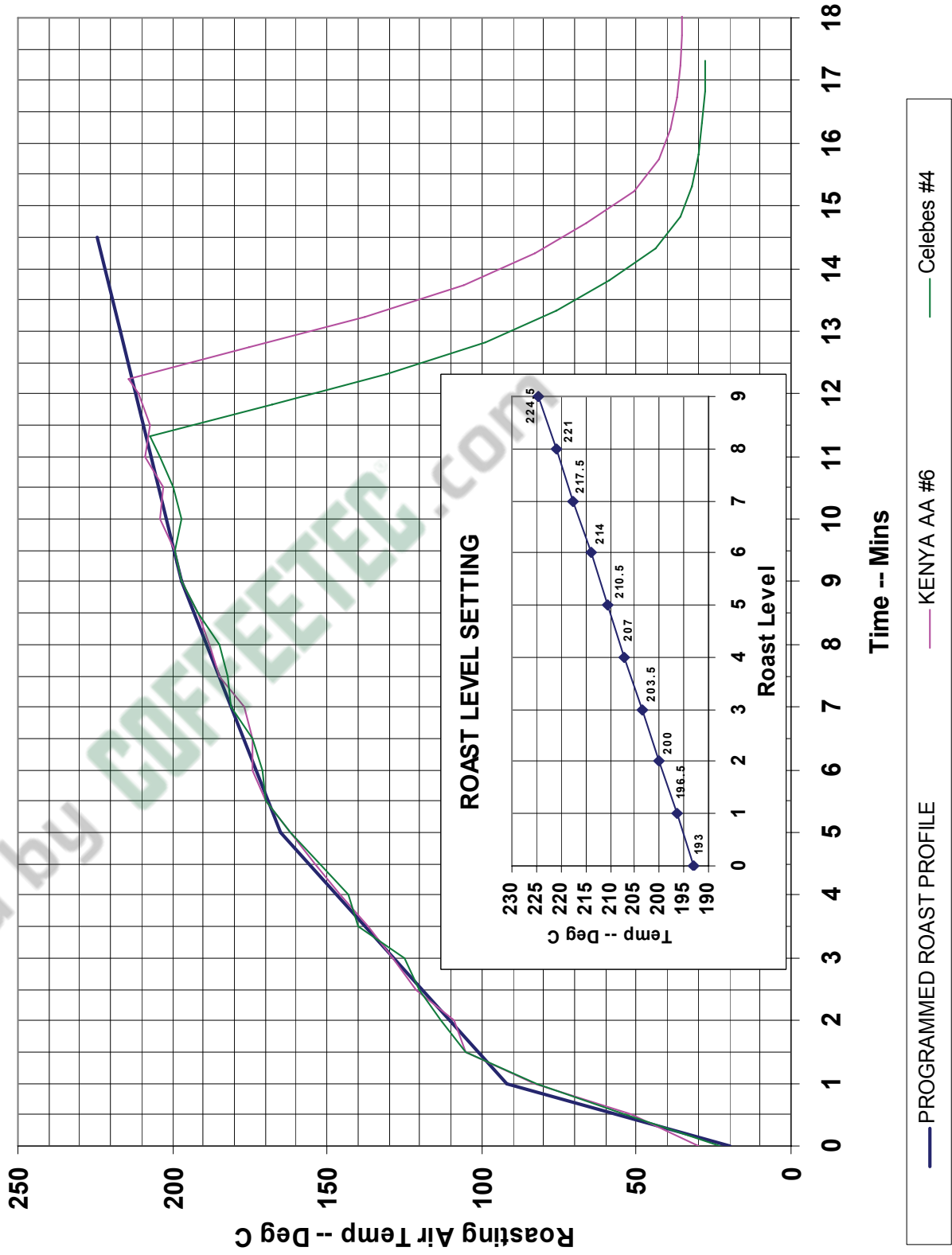

18. Warranty Information

sonofresco warrants the truly fresh coffee roaster against defects in workmanships or materials for a period of one year from the date of purchase as follows:

1. If the product is determined to be defective, sonofresco will repair or replace the product free of charge.
2. This warranty does not cover replacement of the glass roasting chamber, the chaff screen, or gaskets.
3. This warranty does not cover problems resulting from poor installation or operator abuse. Roasting anything other than green coffee beans in the machine will void the warranty.

Repair or replacement as provided under this warranty is the exclusive remedy of the purchaser. sonofresco shall not be liable for any incidental or consequential damages for breach of any express or implied warranty on this product.

Hosted by COFFEEBEE.com

There are four models of the sonofresco coffee roaster. The roasters all follow the same roast profile, and have the same capacity-each roasting about 2.8 pounds per cycle. All of the machines will use about 350 watts of electric power. The heating in all machines is supplied by either propane or natural gas.

The four models are:

Model 2100-Propane, 120 vac, 60 hz, 3 amp

Model 2200-Natural Gas, 120 vac, 60 hz, 3 amp

Model 2300-Propane, 230 vac, 50 hz, 1.5 amp

Model 2400-Natural Gas, 230 vac, 50 hz, 1.5 amp

Input Ratings:

Propane - 48,000 btu/hr

Natural Gas- 48,000 btu/hr

Units intended for 50 hz usage will not operate properly on 60 hz and vice versa. Units intended for natural gas will not operate properly if run on propane. Units intended for propane will not operate properly on natural gas.

All models weigh approximately 55 pounds (25 kilos), and are 15 inches (28.6 cm) by 21-3/4 inches (48.3 cm) by 29 inches (68.6 cm) high.

Models 2100 and 2200 are designed and tested for use in the U.S. and Canada to the following standards:

Gas-Fired Food Service Equipment In accordance with:

American National Standards Institute ANSI Z83.11b

Canadian Gas Association CGA 1.8b-2000

sonofresco
1365 Pacific Drive
Burlington, WA 98233
(360)757-2800
(360)757-8172 Fax
www.sonofresco.com