

MILL CITY ROASTERS®

MCR500



# INSTALLATION MANUAL

500 GRAM GAS SAMPLE COFFEE ROASTER

Mill City Roasters®  
401 Harding Street NE,  
Minneapolis, MN 55413

Phone: +1 (612) 886-2089  
Email: [sales@millcityroasters.com](mailto:sales@millcityroasters.com)  
Online: [millcityroasters.com](http://millcityroasters.com)

*March 28, 2025*

 Note: Owner must post in a prominent location instructions to be followed in the event the operator smells gas or otherwise detects a gas leak. These instructions shall be obtained by consulting the local gas company or gas supplier.

 Note: This manual shall be retained for future reference.

** FOR YOUR SAFETY**

**Do not store or use gasoline or other flammable vapors and liquids in the vicinity of this or any other appliance.**

** WARNING**

**Improper installation, adjustment, alteration, service or maintenance can cause property damage, injury or death. Read the installation, operating and maintenance instructions thoroughly before installing or servicing this equipment. Disconnect all power before performing maintenance or repairs.**

** WARNING**

**Keep the appliance area free and clear of combustibles.**

**Keep the flow of combustion and ventilation air free of obstruction.**

THIS PAGE INTENTIONALLY LEFT BLANK

# TABLE OF CONTENTS

## PART ONE: OVERVIEW

|                        |    |
|------------------------|----|
| SPECIFICATIONS         | 8  |
| ROASTER LAYOUT         | 10 |
| CONTROL PANEL OVERVIEW | 17 |
| SPACE PLANNING         | 18 |
| VENTING                | 19 |

## PART TWO: GAS & POWER

|       |    |
|-------|----|
| GAS   | 23 |
| POWER | 28 |

## PART THREE: IGNITION & ADJUSTMENTS

|                           |    |
|---------------------------|----|
| ROASTER SAFETY            | 32 |
| IGNITION                  | 34 |
| DRUM SEASONING ROASTS     | 35 |
| CLEANING & MAINTENANCE    | 36 |
| DRUM GAP ADJUSTMENT       | 39 |
| TORQUE LIMITER ADJUSTMENT | 40 |
| WARRANTY                  | 42 |
| CONTACT                   | 43 |

# PART ONE: OVERVIEW

# 500 GRAM GAS SAMPLE COFFEE ROASTER



Model: MCR500  
Capacity: 500 Grams





Mill City Roasters®, Minneapolis, MN, USA

# SPECIFICATIONS

| Model Information                 |  |   |
|-----------------------------------|--|---|
| General                           | <ul style="list-style-type: none"> <li>- Intended for use on table or workbench</li> <li>- Integrated chaff collector</li> <li>- Manual cooling stirring</li> <li>- Requires power, gas and exhaust venting</li> </ul> |   |
| Dimensions & Clearances           |  |   |
| Roaster Size (L x W x H) / Weight | 37.78 in x 17.81 in x 30.04 in (95.9 cm x 45.2 cm x 76.3 cm) / 77 lb (35 kg)   |   |
| Clearances to Combustibles        | 18 in (45.72 cm)   |   |
| Capacity / Output                 |  |   |
| Batch Size                        | 0.1 kg - 0.6 kg  |   |
| Batch Time                        | < 15 minute batch  |   |
| Production Output                 | 4.4 lb/hr, 35.3 lb/day (2 kg/h, 16 kg/day)   |   |
| Drum Size (Ø x L)                 | 6.5 in x 6.4 in (16.51 cm x 16.256 cm)   |   |
| Drum Construction                 | Double-walled Drum, 430 Stainless Steel, Welded  |   |
| Cooling Tray Size (Ø x D.)        | 9.84 in x 3.75 in (25 cm x 9.525 cm)   |   |
| Data Logging                      |  |   |
| Connection                        | Integrated USB connection via MODBUS   |   |
| Temperature Data                  | BT, ET, DT   |   |
| Roaster Data                      | Fan Speed and Drum Pressure  |   |
| Power                             |  |   |
| Electrical Service Required       | Single Phase, 220-230V, 15A, 50-60Hz   |   |
| Electrical Connection             | Nema 6-15p   |   |
| Light Bulb                        | 220V LED   |   |
| Gas                               |  |   |
| Fuel Type                         | LP Gas or Natural Gas. Factory-installed orifices are sized for LP Gas. Natural Gas conversion kits are available. Gas conversions to be completed by owner using orifices and instructions provided by manufacturer.  |   |
| Fuel Input                        | LP Gas: 6,400 Btu/hr / Natural Gas: 8,400 Btu/hr   |   |
| Gas Connection                    | 1/2" NPT   |   |
| Gas Service Pressure              | <u>Required for CSA Installations*</u><br>LP Gas: 11" of water column<br>Natural Gas: 7" of water column   | <u>Suggested for Non-CSA Installations**</u><br>LP Gas: 14" of water column<br>Natural Gas: 14" of water column   |
| Gas Regulator                     | <u>Required for CSA Installations*</u><br>LP Gas: Maxitrol 325-3<br>(Adjusted to 9" of water column)<br>Natural Gas: Maxitrol 325-3<br>(Adjusted to 5.5" of water column)  | <u>Suggested for Non-CSA Installations**</u><br>LP Gas: Maxitrol 325-3 with Red Spring<br>(Adjusted to 14" of water column)<br>Natural Gas: Maxitrol 325-3 with Red Spring<br>(Adjusted to 14" of water column) |
| Burner Control                    | Manual Valve   |   |
| Number of Burners                 | 2  |   |

(continued on next page)

(continued from previous page)

| Exhaust Fans  |   |   |  |
|---|---|---|--|
| Exhaust System  | Power-vented, dual exhaust.   |   |  |
| Roaster Exhaust Fan   | Description   | Pulls exhaust from drum, pushes through chaff collector to termination outdoors.  |  |
|   | Volume  | 78 CFM (max.) Typical variable high-medium-low use throughout batch.  |  |
| Cooling Tray Exhaust Fan  | Description   | Pulls exhaust from cooling tray, pushes to termination outdoors.  |  |
|   | Volume  | 117 CFM (max.) Typical use is max airflow for 2-3 minutes at end of batch.  |  |
| Venting   |   |   |  |
| Venting Type  | Positive pressure ducting is required for all venting. Venting near components should disassemble for easy cleaning. Venting beyond chaff collector should be arranged to allow for sweeping/cleaning.  |   |  |
| Venting Direction   | Exhaust can be vented vertically or horizontally. See below for length limitations.   |   |  |
| Venting Layout  | Roaster exhaust is required to pass through chaff collector and beyond to termination outdoors. Cooling Tray exhaust is required to terminate outdoors. <b>Two lines may be merged into one line after the chaff collector using the MCR Venting Kit. If MCR Venting Kit is used, requirements below for the line between chaff collector and termination outdoors will govern beyond end of kit.</b> |   |  |
| Roaster Exhaust Venting   | Line between Roaster & Chaff Collector  | Included. Chaff collector is integrated into roaster body. No additional venting required between roaster & chaff collector.  |  |
|   | Line between Chaff Collector & Termination Outdoors   | Heat Rating   | 500°F  |
|   |   | Size  | 3"Ø (nominal, line can be increased in diameter)   |
|   |   | Max. Length   | ***Recommended maximum venting run is 20 feet (decrease by 5 feet for each 90 degree elbow or equivalent).   |
|   |   | Clearance to Combustibles   | Installations with combustibles at the roof/wall penetration or within 18" of venting will require a double-wall venting product with appropriate clearance-to-combustible rating. |
| Condensation  | Insulated duct or lining is suggested in cold environments (interior or exterior) to prevent excessive condensation inside venting.   |   |  |
| Cooling Tray Exhaust Venting  | Line between Cooling Tray & Termination Outdoors  | Heat Rating   | 390°F <i>when carrying cooling tray exhaust ONLY.</i>  |
|   |   | Size  | 3"Ø (nominal, line can be increased in diameter)   |
|   |   | Max. Length   | ***Recommended maximum venting run is 20 feet (decrease by 5 feet for each 90 degree elbow or equivalent).   |
| Venting Kits & Termination Outdoors   | See <i>Venting</i> section in manual for information.   |   |  |
| Certifications  |   |   |  |
| All Models:   |   | MCR Series Models Only:   |  |
|    |   |   <ul style="list-style-type: none"> <li>• ANSI Z83.11</li> <li>• CSA 1.8-2016</li> <li>• Food Service Equip.</li> <li>• Not intended for household use.</li> </ul> |  |

\*CSA Certification is only available on model MCR500 and other MCR Series models.

\*\*Contact Mill City Roasters® for more information on optimizing fuel pressure to increase batch size/output.

\*\*\*Extending venting lines beyond recommendations can cause back-flow, decreased airflow capacity, and chaff dispersal. Contact Mill City Roasters for strategies to minimize lengths or counteract side effects of long vent runs.

Assembled in China.

# ROASTER LAYOUT

|     |   |  |  |
|-----|---|--|--|
| R1  | Control Panel                                 |  |  |
| R2  | Cooling Tray                                  |  |  |
| R3  | Hopper  |  |  |
| R4  | Roaster Exhaust Fan                           |  |  |
| R5  | Chaff Collector                               |  |  |
| R6  | Access Panel To Chaff Collector               |  |  |
| R7  | Access Panel To Burners                       |  |  |
| R8  | Drum Body Cover                               |  |  |
| R9  | Gas Pressure Gauge                            |  |  |
| R10 | Analog Temperature Gauge                      |  |  |
| R11 | Digital Drum Pressure Gauge                   |  |  |
| R12 | Tryer   |  |  |
| R13 | Hopper Chute Lever                            |  |  |
| R14 | Drum Door Lever                               |  |  |
| R15 | Drum Door                                     |  |  |
| R16 | Drum Shaft                                    |  |  |
| R17 | Lamp  |  |  |
| R18 | Lamp Switch                                   |  |  |
| R19 | Sightglass                                    |  |  |
| R20 | Emergency Stop                                |  |  |
| V1  | Port - Chaff Collector Exhaust Outlet         |  |  |
| V2  | Port - Cooling Tray Exhaust Outlet            |  |  |
| G1  | Power Cord Location                           |  |  |
| G2  | Gas Inlet                                     |  |  |
| T1  | Thermocouple - (BT) Bean Temperature          |  |  |
| T2  | Thermocouple - (ET) Environmental Temperature |  |  |
| T3  | Thermocouple - (DT) Drum Temperature          |  |  |
| C1  | Access Panel                                  |  |  |
| C2  | Levelling Legs                                |  |  |

# ROASTER - TOP VIEW

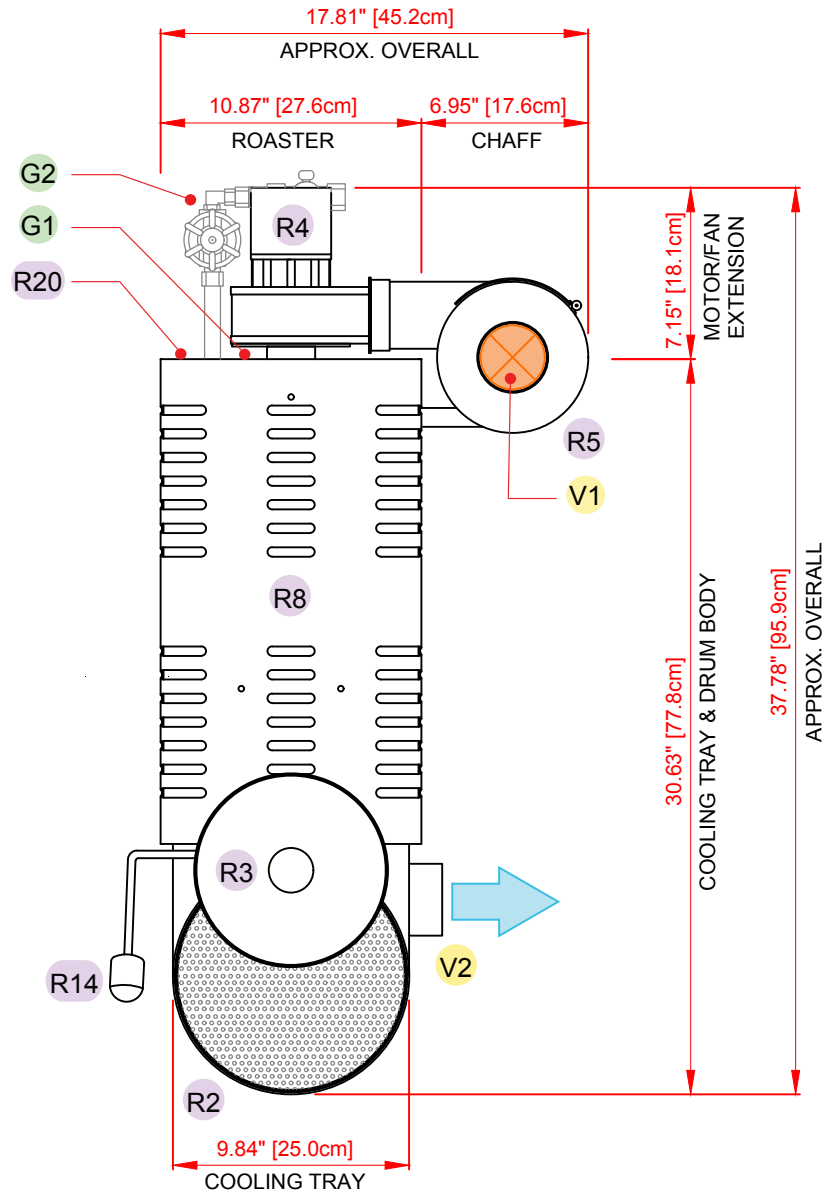

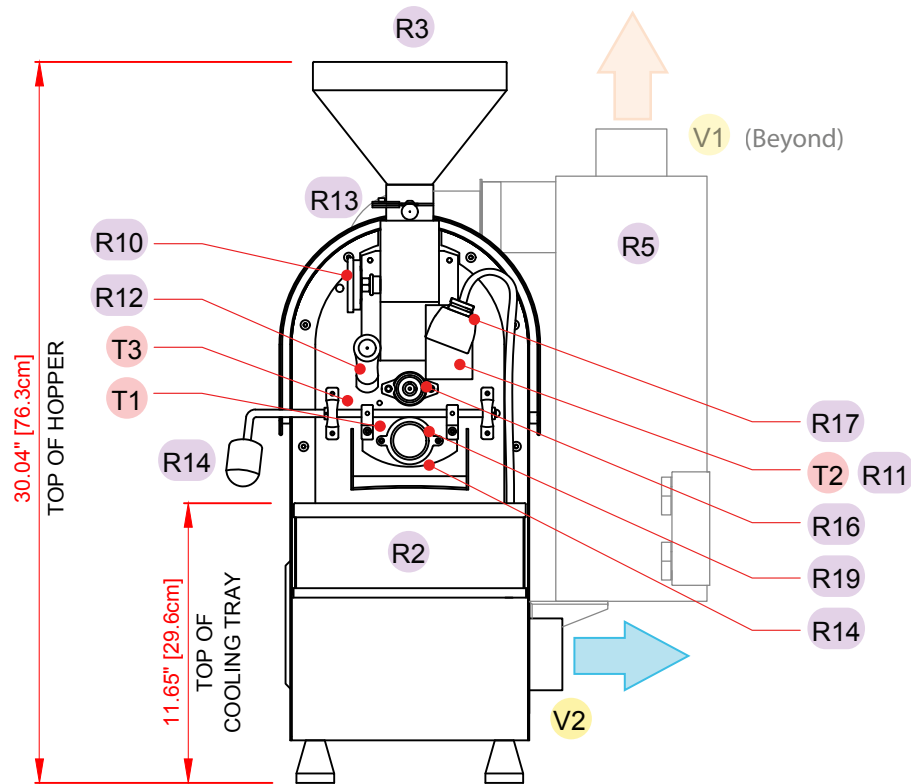

# ROASTER - LEFT SIDE (CONTROL PANEL SIDE)

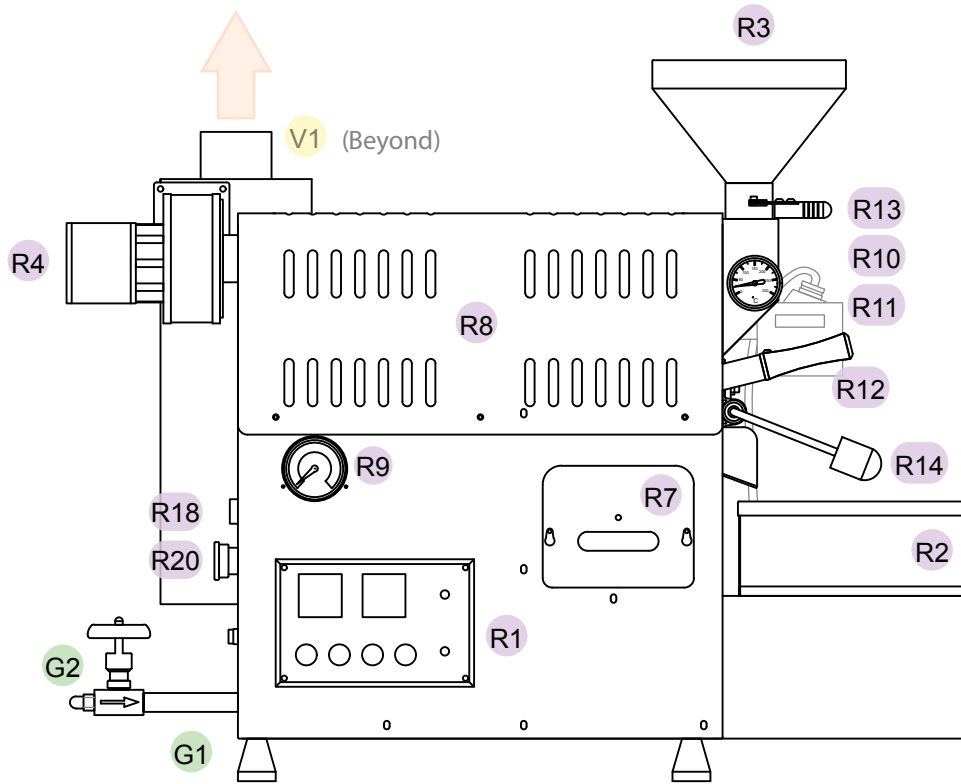

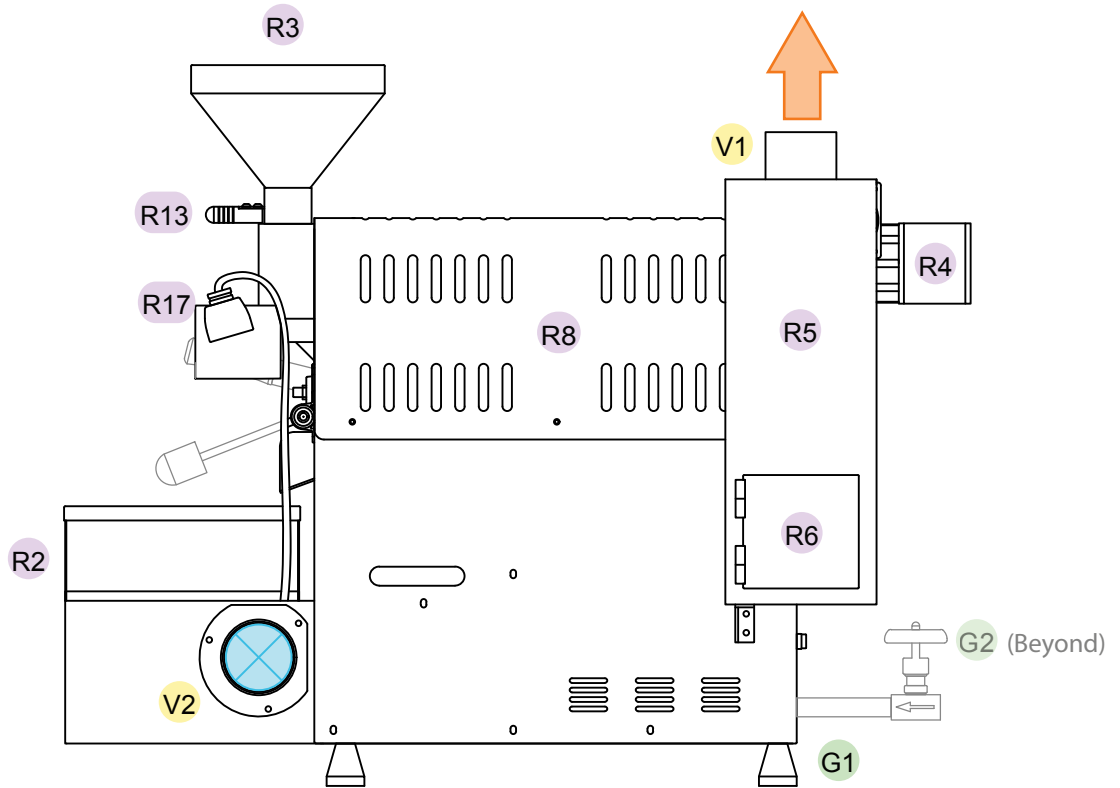

# ROASTER - REAR

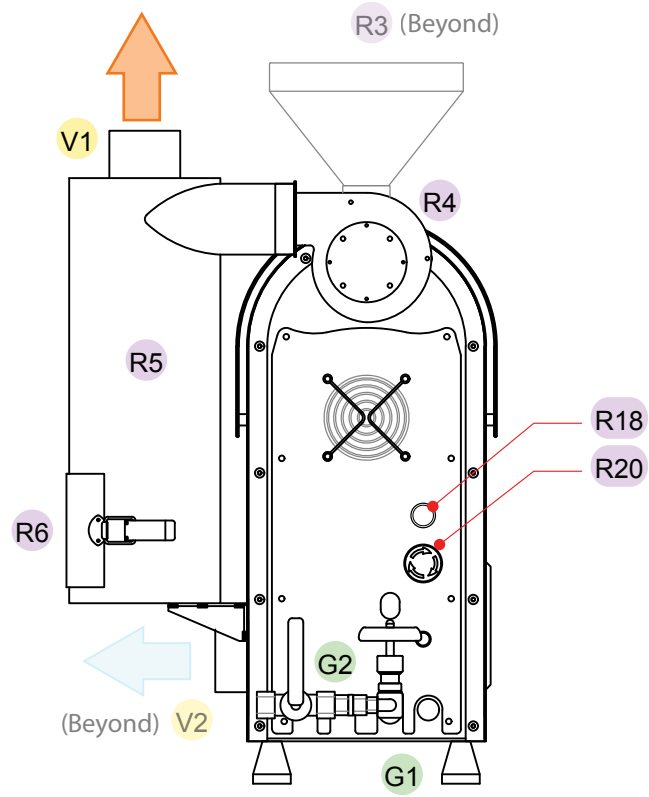

# CONTROL PANEL OVERVIEW

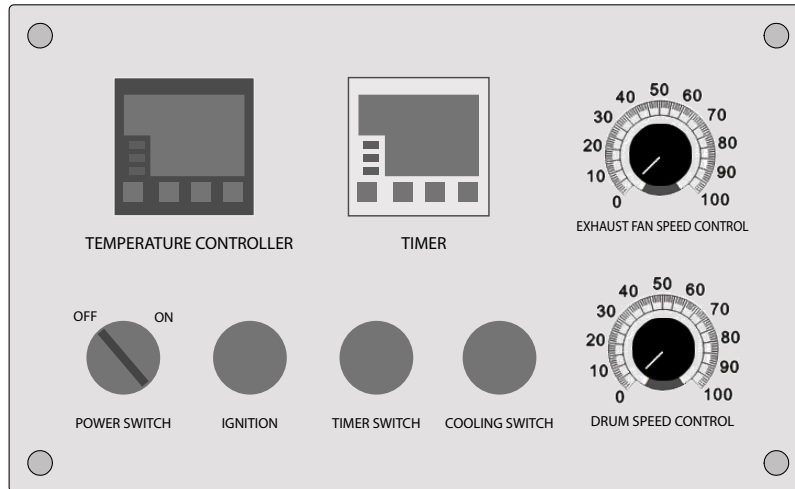

Temperature Controller: Heating limit controller. Set to factory maximum temperature for preheat and finish temp. Turns off at set point and turns on again after 30F decrease in temp.

Timer: Elapsed roast time

Power Switch: Main power switch

Ignition: Burner ignition switch

Cooling Switch: Starts and stops cooling tray fan.

Timer Switch: Starts and stops roast timer.

Exhaust Fan Speed: Fan speed adjustment

Drum Speed: Drum speed adjustment

Emergency Stop Button: Disables drum motor, fan motors, and ignition system.

# SPACE PLANNING

## Considerations when installing a commercial coffee roaster

### Fire & Building Safety

1. Verify with local zoning regulations that coffee roasting is allowed on the property.
2. Venting Termination: Identify a viable exhaust termination point through the roof or exterior wall based requirements and recommendation in this manual. Check your local municipal building & mechanical codes for regulations regarding exhaust locations of combustion gas. The requirements of your local authorities will govern in the event they exceed the recommendations made in this manual. See Specifications for maximum recommended venting line lengths and contact Mill City Roasters® for alternative venting strategies if this recommendation cannot be met.
3. Clearance to Combustibles: Maintain 18” clearance to combustibles on sides and top of roaster components and any single-wall venting provided by Mill City Roasters®. Components can be placed on combustible floor when included feet are installed. When possible, we recommend allowing a minimum of 24” of clearance on non-working sides of roaster, chaff collector and venting for cleaning access and proper maintenance.
4. Cleaning & Fire Safety: When placing roaster, maintain easy access to doors of chaff collector and clearance to allow for frequent removal of chaff.
5. Check your local fire code. Ensure final placement of equipment and supplies does not impede required egress paths. The requirements of your local & state authorities will govern in the event they exceed the recommendations made in this guide.
6. Evaluate proximity of heat-triggered fire suppression systems (i.e. sprinkler heads) to the roasting components.

### Consumer Safety

1. Verify requirements for a roasting operation with your local health department. Certain municipalities may have requirements including three compartment sinks, hand wash stations, mop sinks, wall & flooring materials, work surface types, rodent abatement, signage, cleaning regimen, light bulb covers etc. A certificate or license may be required to operate and/or sell coffee/food for consumption.

### Utilities

1. Review power and gas requirements for your roaster. For new spaces, if gas pressure is unknown, we suggest having the gas pressure measured prior to signing a lease or purchase agreement. Contact us for information on increasing available gas pressure if required.

### Size & Scale

1. Roasting Tools & Supplies: Immediately around the roaster, plan for laptop for data logging, separate containers for green coffee and roasted coffee, vacuum for chaff, fire safety tools such as drum crank and spray bottle. Adjacent to the roaster you may also require staging area, work surface for queueing green coffee and weighing batches.
2. Cupping Area: Space and work surfaces to cup roasted coffee for sample evaluation, profile design and quality control. Space may require grinder, brewers, kettles/towers, wares, etc.
3. Shipping & Receiving: Roasteries of all sizes may benefit from dock access, pallet jacks, lifts to move product. Note: not having dock or lift access for delivery trucks may significantly increase your shipping expenses.
4. Additional Green Coffee Storage: If your on-site storage needs exceed short term use, you may require a dedicated area. Your greens importer can help you understand how to safely store coffee for use over several weeks.
5. Packaging Area: Processing roasted coffee for retail or wholesale. May include grinding for customers. Space may be subject to health department approval.
6. Inventory & Fulfillment: Area for processing orders, preparing shipments and organizing for carrier pickups.
7. Note: It is very common that owners will need to upgrade to larger roasters at some point. Contact us to discuss strategies to consider to plan your space for scaling including flexible space design and installing venting, gas & wiring appropriate for both your current and future equipment.

### Beyond Roasting: Facilities & Access

1. If you plan to have employees and/or allow the public in your space, check your local workforce requirements, applicable commercial building codes, and guidelines for retail businesses serving the public.

# VENTING



## FIRE DANGER

**Fires can be caused by not keeping venting & chaff collector free of build-up and using improper venting could allow fire to spread to your building. Follow the venting specifications and installation guidelines and keep your venting & chaff collector clean.**

| Venting Ports (Size / Run) |   |
|----------------------------|---|
| Cooling Fan Exhaust        | 3"Ø (nominal) / cooling tray -to- termination outdoors    |
| Cooling Tray Exhaust Port  | 3"Ø (nominal) / chaff collector -to- termination outdoors |

\*Port diameters noted are nominal. Field verification is highly suggested.

**SPECIFICATIONS:** See SPECIFICATIONS for information on positive pressure, dual exhaust system. Find more general venting information and FAQ here: <https://millcityroasters.com/commercial-coffee-roaster-venting/>

**SINGLE & DOUBLE WALL:** If your venting will be within 18" of combustible materials in your building (both being in proximity to and/or at the penetration of building envelope to reach termination outdoors), you may be required to use double-wall, positive pressure venting. Follow the venting manufacturers published clearances to combustibles and all applicable building and mechanical codes.

**MAXIMUM LENGTHS/RUNS:** See SPECIFICATIONS for recommended maximum venting lengths. For best performance, place your roaster where it can be immediately vented out a wall or through a roof. Air flow issues caused by long or complex venting runs are not supported by our tech support team but we may be able to consult on venting strategies to minimize your issues.

**CAPS AT TERMINATIONS:** Vertical terminations should have simple rain caps (no screens or fins) that stand off the top of the stack at a height equivalent to the diameter of the stack. Horizontal terminations should extend past the face of the exterior wall a minimum of 12" for non-combustible surfaces and 24" for combustible surfaces, be turned downward using a 30 degree or 45 degree elbow and have a simple bird or rodent screen cap applied (no tight screens).

### NOT ALLOWED:

1. Negative pressure ducting/venting types such as Class B or L or A venting, or stovepipe are not allowed.
2. Reducing diameters of ducting to be smaller than port size is not allowed.
3. Flexible duct of any rating or type is not allowed.
4. "T" shaped intersections/clean-outs or "L" shaped elbows with zero radius.
5. Termination caps with fins or insect screens that limit airflow.

Using unapproved, uncertified venting may void the warranty on your roaster and all parts & accessories

### NOT SUGGESTED:

1. Low radius elbows (with a center line radius that is less than the pipe diameter).
2. Ganging multiple roasters together - even when gating is used to isolate systems.
3. Clean-out doors or intersections in venting lines that disrupt airflow.

Any of these situations may limit our ability to diagnose airflow issues or provide general tech support.

THIS PAGE INTENTIONALLY LEFT BLANK

This concludes Part One: Overview

Mill City Roasters®, LLC.  
401 Harding Street NE,  
Minneapolis, MN 55413

Phone: +1 (612) 886-2089  
Email: [sales@millcityroasters.com](mailto:sales@millcityroasters.com)  
Online: [www.millcityroasters.com](http://www.millcityroasters.com)

## PART TWO: GAS & POWER

## GAS

**⚠ INSTALLATION MUST CONFORM WITH LOCAL CODES**

In the absence of local codes, installation must conform with *National Fuel Gas Code*, ANSI Z223.1/NFPA 54, or the *Natural Gas and Propane Installation Code*, CSA B149.1, as applicable

**⚠ FOR YOUR SAFETY**

The roaster and pressure regulator must be isolated from the gas supply piping system during any pressure testing of that system at test pressures in excess of 1/2 psi (3.5 kPa).

THIS PAGE INTENTIONALLY LEFT BLANK

# GAS INSTALLATION

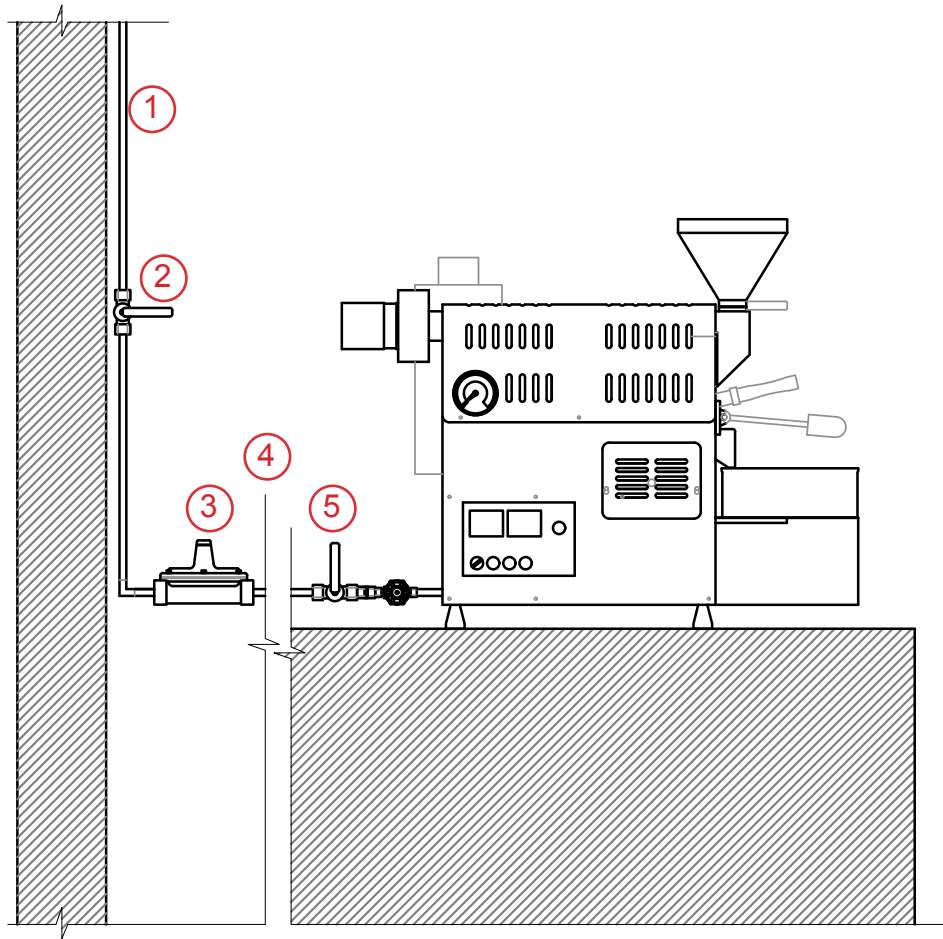

|   |                      |   |   |
|---|----------------------|---|---|
| ① | Existing Gas Service | Supplied by Owner<br>Installed by Owner     | See roaster specifications for gas pressure required.   |
| ② | Gas Shut-Off Valve   | Supplied by Owner<br>Installed by Owner     | Shut-Off Valve required on service side of regulator & roaster. Regulator & roaster must be isolated from the gas supply piping system during any pressure testing of the gas supply piping system at test pressures equal to or less than 1/2 psi (3.5 kPa).<br><br>Locate this shut-off valve in an accessible location to allow for daily shut off when roaster is not in use. |
| ③ | Gas Regulator        | Supplied by Owner<br>Installed by Owner     | Maxitrol regulator required. See specifications for required Maxitrol regulator model and required pressure adjustments to be made per gas type.  |
| ④ | Gas Line to Roaster  | Supplied by Owner<br>Installed by Owner     | Use rigid or flexible gas line as appropriate for location and gas service. Verify layout with operator prior to installation.  |
| ⑤ | Gas Shut-Off Valve   | Located on roaster<br>(no install required) | Gas Shut-off valve with 1/2" BSPT connection.   |

## CONVERTING GAS FUEL TYPE (CONTINUED ON NEXT PAGE)

Your roaster arrives with orifices sized for LP Gas already installed. If you need to convert your roaster to use Natural Gas, install the Natural Gas orifices included in your roaster kit. You will be required to replace each orifice using the instructions below.

NOTE: This is a relatively simple procedure but requires the use of tools and a basic understanding of gas installation process. If you feel this is beyond your capability, please contact a local gas installation professional for assistance.

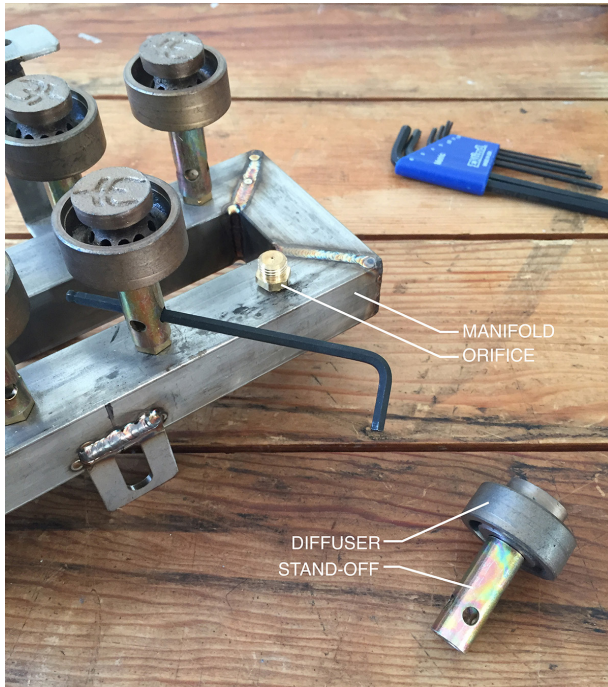

One orifice is located inside the base of each of the burners. For clarity, the photos on the bottom left show the manifold removed from the machine but it is not required that you remove the manifold from the roaster.

1. Unscrew each burner (stand-off and diffuser) from the manifold to reveal the orifice (brass) below. It may be helpful to use a 4mm allen wrench as shown through the stand-off.
2. Once exposed, orifices can be removed by unscrewing the orifice itself using either a 12mm wrench or socket.
3. Reassemble using the correct orifice for your fuel type.
4. Reinstall burners inside roaster.
5. Continued on next page.



(CONTINUED FROM PREVIOUS PAGE)

5. Locate Gas Plate on back of roaster and apply orange conversion label supplied with orifices to note conversion.

 **Note:** Gas conversion is not complete until conversion label is applied to Gas Plate as shown.

This roaster can use LP Gas or Natural Gas. Factory-installed orifices are sized for LP Gas. To safely convert to Natural Gas, see conversion instructions for orifice replacement and apply below the conversion label supplied with orifices to note conversion.

This roaster requires a regulated gas supply. See machine specifications for required gas regulator information and required regulator pressure settings.

|                          |        |
|--------------------------|--------|
| LP Gas Pressure          | 11" WC |
| LP Gas Orifice Size      | 0.6 mm |
| Natural Gas Pressure     | 7" WC  |
| Natural Gas Orifice Size | 0.9 mm |

This roaster has been converted to use Natural Gas.  
*Ce torréfacteur a été converti pour utiliser du Gaz Naturel.*

*Ce torréfacteur peut utiliser du gaz LP ou du gaz naturel. Les orifaces installés en usine sont dimensionnés pour le gaz propane. Pour convertir en toute sécurité en gaz naturel, reportez-vous aux instructions de conversion pour le remplacement d'oriface et appliquez-le au-dessus de l'étiquette de conversion fournie avec orifaces pour effectuer la conversion.*

*Ce torréfacteur nécessite une alimentation en gaz réglementée. Reportez-vous aux spécifications de la machine pour obtenir les informations requises sur le régulateur de gaz et les réglages de pression requis.*

|                                    |          |
|------------------------------------|----------|
| Pression de Gaz LP                 | 2.74 kPa |
| Taille de l'orifice de Gaz LP      | 0.6 mm   |
| Pression de Gaz Naturel            | 1.74 kPa |
| Taille de l'orifice de Gaz Naturel | 0.9 mm   |

## POWER

**⚠ INSTALLATION & GROUNDING MUST CONFORM WITH LOCAL CODES**  
In the absence of local codes, installation and grounding must conform with *National Electrical Code, NFPA 70*, or the *Canadian Electrical Code, CSA C22.2*, as applicable.

**⚠ WARNING**

**Electrical Grounding Instructions:** This appliance is equipped with a three-prong (grounding) plug for your protection against shock hazard and should be plugged directly into a properly grounded three-prong receptacle. Do not cut or remove the grounding prong from this plug.

**⚠** Roasters require a dedicated branch circuit and installation of applicable receptacles. See specifications of individual machines for voltage, phase, frequency and amperage and connection.

**⚠ WARNING**

**Disconnect power before performing maintenance or repair work.**

# ELECTRICAL CIRCUIT DIAGRAM

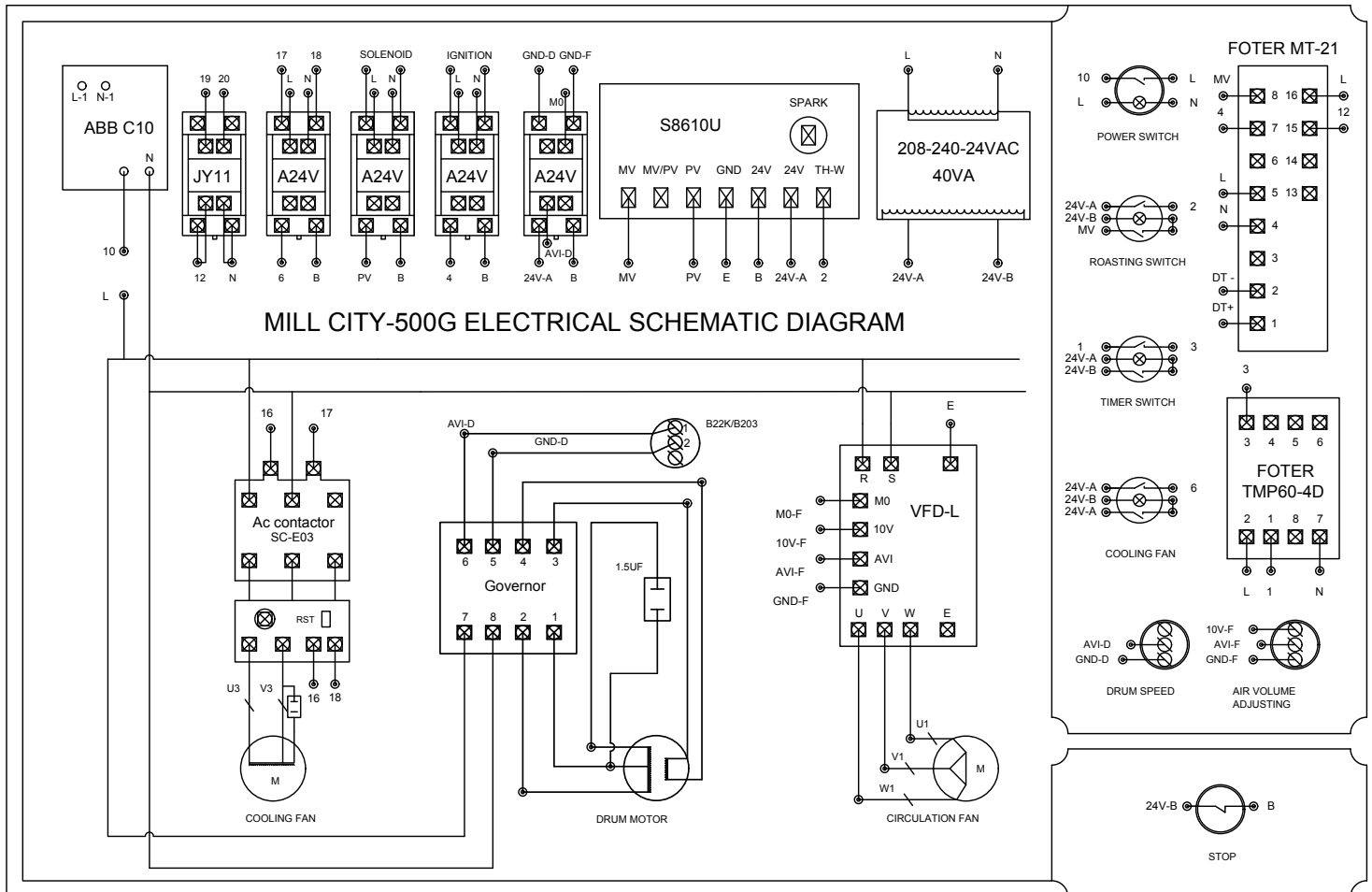

Electrical circuit diagram is also mounted to inside surface of door or body of roaster near the electrical circuits.

This concludes Part Two: Gas & Power

If you have further questions, contact us.

Mill City Roasters®, LLC.  
401 Harding Street NE,  
Minneapolis, MN 55413

Phone: +1 (612) 886-2089  
Email: [sales@millcityroasters.com](mailto:sales@millcityroasters.com)  
Online: [www.millcityroasters.com](http://www.millcityroasters.com)

# PART THREE: IGNITION & ADJUSTMENTS



# ROASTER SAFETY

- ⚠ This roaster is industrial machinery and must only be used by experienced, trained operators.**
- ⚠ While in operation, never leave the roaster unattended.**
- ⚠ Do not block or obstruct flow combustion air into the combustion chamber or ventilation exhaust.**
- ⚠ When finished roasting, turn off gas at the source.**
- ⚠ Disconnect power before performing any kind of maintenance or repair work.**
- ⚠ Surfaces of the roaster, chaff collector and venting will be hot during and after roasting. Maintain 18” clearance between machinery/venting and combustibles.**
- ⚠ Be aware of your surroundings when operating and keep children and untrained individuals away from the roaster, fans, chaff collector and venting.**
- ⚠ Restrain long hair, remove jewelry and do not wear loose-fitting clothing or other items that can be potentially caught in the moving parts of the roaster. Failure to comply may result in severe injury or death.**
- ⚠ Never put hands or fingers inside the rear chain guard, roasting drum or cooling tray while the roaster is operating.**
- ⚠ Clean chaff collector and venting regularly to avoid fire.**
- ⚠ Roasters with casters must have all casters locked at all times while gas is present in gas line.**

## SAFETY FEATURES



**EMERGENCY STOP (above):** The emergency stop button is either located on the back of your roaster or the right side of the control panel. Once pressed, it will disable all fans, motors, and gas flow.

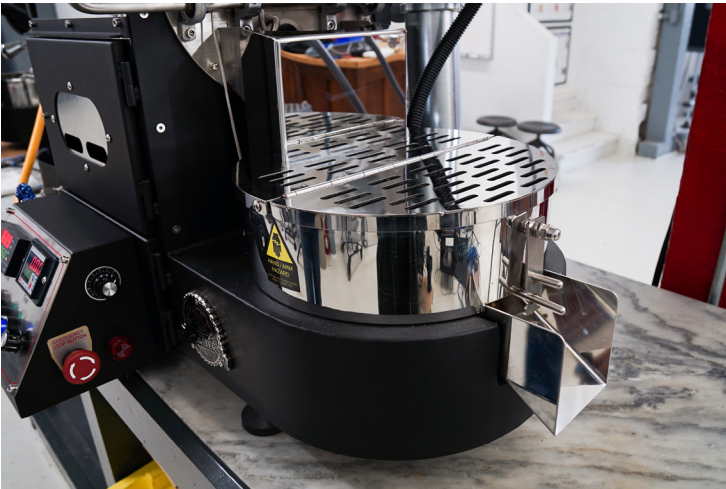

**COOLING TRAY COVER (above):** Cooling tray arms will NOT rotate if the cooling tray cover is open or removed or the sensor cable is unplugged.



**MANUAL DRUM TURNING/COOLING (above):** In case of power outage, use included hand crank (left) to turn drums from rear shaft access on 2kg roasters and above until roast is safely cooled. For roasters 2kg and smaller (right), use an 8mm Allen wrench (not included) to turn drum shaft from the front. Additionally, spraying water on to the roast through the tryer hole may help cool the roast faster.

# ROASTER IGNITION & SHUT DOWN

## **TO IGNITE BURNERS**

1. Turn power switch to 'ON'.
2. Set drum rotation to 50 rpm.
3. Set exhaust fan to minimum setting to draw air through the roaster.
4. Press 'ROASTER SWITCH' once and slowly open gas valve until burners ignite.

## **TO SHUT OFF BURNERS DURING ROASTING**

1. Press 'ROASTER SWITCH' once.

## **TO SHUT DOWN ROASTER**

1. Close gas valve.
2. Turn drum speed to low.
3. Allow roaster drum to fully cool.
4. Turn power switch to 'OFF'.

# DRUM SEASONING ROASTS

The drums of new coffee roasters which have never roasted coffee must be seasoned before roasting any coffee that will be consumed. To season, you will roast several batches of greens to a very dark roast that will allow the oils from the roasted coffee coat the inside of the drum. The coffee will be discarded after it cools. Inexpensive 'Seasoning Greens' are available for purchase from [millcityroasters.com](http://millcityroasters.com).

## **HOW TO SEASON YOUR DRUM**

- A. Preheat roaster to 350F.
- B. Airflow at minimum (view Roasting 101 on Youtube: <https://www.youtube.com/watch?v=bIDMsEQ27DY>)
- C. Gas at 70%
- D. With full capacity charge (500 grams on 500 gram roaster, 2 kg on 2 kg roaster, etc.) allow roast to run straight through to 2nd crack. Record time and temperature of the roast phases: green/yellow transition, first crack, and second crack. There will be much smoke.
- E. About 30 seconds into second crack, turn off the burners and allow the beans to slowly cool in the drum.
- F. Repeat 5-7 times modulating heat for roasts 3 and 4 to hit green/yellow transition around 320F at 5 minutes, 1st crack about 390F at about 9 minutes, and second crack at about 11 minutes.
- G. For roasts 5-7, increase air to medium low after green/yellow transition (320F) and again to full medium airflow about 10F prior to first crack. Modulate heat as necessary to hit target phase times.

## DAILY CLEANING & MAINTENANCE

| What to do:   | How to do it:  | Why:  |
|---|--|---|
| Remove chaff build-up inside chaff collector at bottom. | Access the bottom of the chaff collector through the access panel in the side of the chaff collector. Remove all chaff collected between each roast. (Pro Tip: Keep a small vacuum with a long suction tool close by to make this job easy.) | Chaff is highly flammable. Removing chaff is the most important step in preventing chaff fires which could spread through your venting system and building. |
| Clear the metal collection tray below the drum          | Open the access door to the drum compartment. The metal tray below the drum is removable and can be removed and emptied into a waste can.  | Any build-up here could be flammable but more importantly, monitoring the contents of this tray will help you diagnose the need for a drum gap adjustment.  |

## WEEKLY CLEANING & MAINTENANCE

| What to do:                | How to do it:  | Why:   |
|----------------------------|--|--|
| Clean the cooling tray     | Wipe, brush, scrape and clear out perforations on bottom surface of cooling tray. Remove any chaff build up from under the perforated surface of the cooling tray. | General good practice to care for all areas that hold consumable products but clearing perforations improves air flow and allows for coffee to be cooled faster. |
| Chaff collector inspection | Open all access doors and inspect interior. Remove any chaff build-up with a wire brush.   | Chaff is highly flammable. Removing chaff is the most important step in preventing chaff fires. Removing build-up also improves airflow.                         |

## QUARTERLY CLEANING & MAINTENANCE

| What to do                             | How to do it   | Why?   |
|--|--|--|
| Inspect & clean venting as required.   | Remove and inspect interior walls of venting and remove all build up of coffee oils and chaff.   | Build-up of coffee oils and chaff can be flammable. Build-up can also narrow the diameter of your venting and limit airflow.   |
| Inspect exterior portions of venting   | Access exterior portions of venting and terminations caps and remove any build-up of coffee oils and chaff especially around termination cap openings. | Build-up of coffee oils and chaff can be flammable. Build-up can also narrow the diameter of your openings and limit airflow causing air to back-flow into your roaster or cooling tray. |
| Lubricate the front and rear bearings. | Use a Zerk grease gun & high temperature grease. One pump per bearing.   | Properly greasing Zerk bearings extends bearing life.  |
| Lubricate the chain                    | Use light chain, oil-based lube. Wipe off excess with clean, dry cloth.  |  |
|  |  |  |

 Shut off all power and gas before performing any maintenance.

## SEASONAL/ANNUAL CLEANING & MAINTENANCE

| What to do   | How to do it  | Why?  |
|--|---|---|
| Inspect & tighten all loose nuts & bolts on roaster. | Locate any loose nuts & bolts and tighten, particularly around cooling tray arms. | Tightening loose nuts & bolts keeps your machine in good working order. Prevents cooling tray nuts/bolts from dropping into roasted coffee. |

 Shut off all power and gas before performing any maintenance.

## DRUM GAP ADJUSTMENT

Drum gap is the clearance between the drum and the faceplate of the roaster. Too small a gap will cause the drum to scrape or rub against that face plate. Too large a gap will result in coffee beans and chaff accumulating under the burners. Drum gap adjustment is commonly necessary during the break in period on new roasters. Excessive need for adjustment can indicate that the drum and/or airflow speed is too low or the front bearing requires lubrication. If this is the case, please contact [support@millcityroasters.com](mailto:support@millcityroasters.com) for troubleshooting and operational tips.

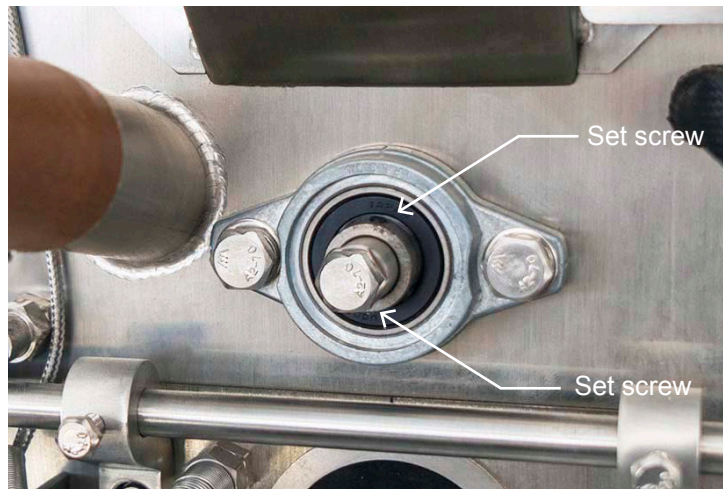

1. Locate the set screws on the front bearings of your roaster drum shaft. There are typically two set screws on opposite sides.



2. Using a hex key wrench, loosen each set screw. The drum will usually move freely to the front or rear. If the shaft won't move, you can use a rubber mallet to lightly tap it from the front or rear.

3. Push on the back of the shaft of the drum to narrow your drum gap or push from the front to increase it. Adjustment is a delicate process and may take several tries as you may need to heat and cool the roaster several times to establish the best possible position.

## TORQUE LIMITER ADJUSTMENT

The torque limiter protects the drum motor in the event the drum jams due to improper drum gap adjustment or the introduction of a foreign object (example: a wayward bolt or your tryer spoon separating from the handle and falling into the drum). The torque limiter consists of two friction disks and a tensioning spring. If your roaster drum doesn't turn when the drum is loaded, it's likely that the torque limiter is set too loose.

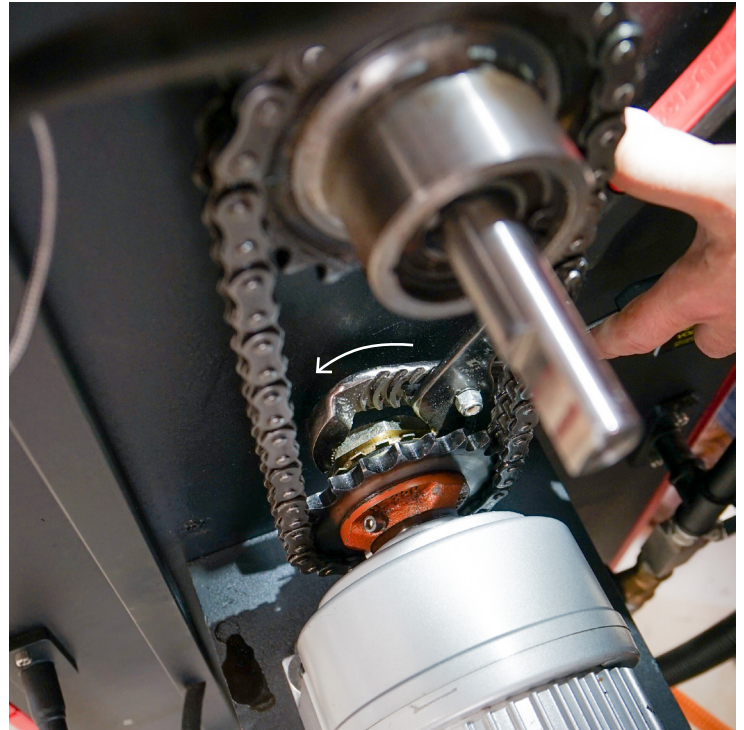

1. Unplug the roaster.
2. Remove the back cover.

The torque limiter is mounted on the motor shaft and drives the chain.

3. With a large wrench, tighten the friction disk assembly only so the drum rotates with a full charge of coffee inside.

This concludes Part 3: Ignition & Adjustments

If you have further questions, contact us.

Mill City Roasters®, LLC.  
1050 33rd Ave SE  
Minneapolis, MN 55414

Phone: +1 (612) 886-2089  
Email: [sales@millcityroasters.com](mailto:sales@millcityroasters.com)  
Online: [www.millcityroasters.com](http://www.millcityroasters.com)



## Mill City Roasters® Warranty

Mill City Roasters® coffee roasting equipment (including coffee roasters, loaders and weigh/fill machines) is intended for commercial use by trained and experienced professional operators. Installation is to be completed by trade professionals. Equipment owners are solely responsible for verifying the proper installation, operation and maintenance guidelines and instructions, complying with all laws and regulations for installation and operation, as well as all industry standard safety practices pertaining to commercial production equipment, commercial coffee roasting activities and commercial coffee roasting equipment.

Mill City Roasters® warrants, to the original purchaser ("Customer"), that 'Fabricated Assemblies & Components' of new coffee roasting equipment ("equipment"), will be free from defects in workmanship and materials, under normal and proper use and maintenance, for a period of two (2) years from the date of delivery. 'Electrical Assemblies & Components' such as motors, switches, relays, ignition modules, data sending units, etc are warranted to be free from defect for a period of one (1) year from the date of delivery. This warranty is limited to repair or replacement of defective parts within the warranty period. Mill City may require that defective parts be returned for inspection and failure analysis. Customer is responsible for on-site diagnostic, shipping, repair, installation, labor, or travel expenses.

Our warranty does not apply to any failure or malfunctioning of equipment, or any of its component or assembly that has been, in Mill City Roasters' judgement, affected by negligence; misuse; abuse; neglect; alteration to equipment or control parameters not authorized by Mill City Roasters; improper installation or operation; lack of or improper maintenance, repair or cleaning; or use of equipment other than for its intended purpose; missing or altered serial nameplates; damage resulting from accidents, natural disasters or criminal activities. Removal of cooling tray cover or modification to any portion of this equipment without prior approval from Mill City Roasters® will void all warranties and render the unit ineligible for support.

In addition, our warranty does not apply to shipping damage; aesthetic or cosmetic damage or defect; defect or wear not affecting operation; normal wear and tear; or parts or items subject to normal wear and use such as gaskets and seals.

To be evaluated for warranty coverage, Customer must first notify Mill City Roasters® of any potential defect prior to the expiration of the Warranty Period via telephone or e-mail so that Mill City Roasters® may provide remote (via email, telephone or video chat service) diagnostics and technical evaluation and support.

If pursuant to the diagnostic and technical evaluation and support, Mill City Roasters® determines in its sole discretion that the equipment contains a defect in workmanship or materials, Mill City Roasters® will provide any replacement parts it deems necessary to repair the defect. Mill City Roasters® will pay for shipping the replacement parts to the Customer via standard shipping for the first 14 days of the Warranty Period, after which the Customer is solely responsible for all shipping expenses.

If remote evaluation and support is not able to determine whether the equipment is defective, or the Customer is unable for whatever reason to complete any repair work recommended by Mill City Roasters, Mill City Roasters® may allow the Customer to return the equipment or affected component to Mill City Roasters® for evaluation or repair. However, the Customer is solely responsible for all shipping expenses related to delivery and return of the equipment or component for the remainder of the Warranty Period.

All defective parts, components and assemblies of the equipment become the property of Mill City Roasters. Mill City Roasters, at its sole option and expense, may request the return of any alleged defective parts, components or assemblies to Mill City Roasters® before the shipment of replacement parts.

Except as stated in the above warranty, Mill City Roasters® shall not be liable for any other repair, replacement or installation expenses, or any other expenses incurred by Customer as a result of any alleged or proved defect. Mill City Roasters® shall not be liable for any special, incidental or consequential damages or losses of any kind, including but not limited to lost profits, lost sales, loss of use of equipment, customer claims, cost of down time.

THE FOREGOING WARRANTY IS EXCLUSIVE AND IS IN LIEU OF ANY OTHER WARRANTY, WRITTEN OR ORAL, EXPRESSED OR IMPLIED, INCLUDING, BUT NOT LIMITED TO, ANY IMPLIED WARRANTY OF MERCHANTABILITY OR FITNESS FOR A PARTICULAR PURPOSE.

The foregoing warranty shall be governed by and construed in accordance with the laws of the State of Minnesota and the laws of the United States of America.

Mill City Roasters LLC  
401 Harding Street NE,  
Minneapolis, MN 55413  
USA

## TECHNICAL SUPPORT

Technical support is available by phone.

Contact us below.

Mill City Roasters®, LLC.  
401 Harding Street NE,  
Minneapolis, MN 55413

Phone: +1 (612) 886-2089  
Email: [hello@millcityroasters.com](mailto:hello@millcityroasters.com)